

# **WRM-5104 Occupancy Detector**

## **Directions & Circuits**



### **CONTENTS**

Parts & Dimensions _____	1a
Specifications _____	1a
Installation Guide _____	1b
Start-up & Adjustment _____	1b
Mounting: Octagon box _____	2a
Mounting: Miscellaneous _____	2b
Sequence of Operation _____	3a
No-Motion Time-Out _____	3a
Sensitivity Adjustment _____	3a
Control Options Switch _____	3b
Override Jumper _____	3b
Method of Detection - PIR _____	4a
Coverage Pattern _____	4b
Coverage Pattern: Application Tips _____	5a
Alignment of Focus Zones _____	5b
Electrical Connections - General Information _____	6a
Wire Size and Type - IMPORTANT _____	6b
Switching Douglas 2-Wire Relays with WRM-5104 _____	7a
Multiple Detectors to Increase Coverage Area _____	7b
Building Wide Override with Timer _____	8a
Retrofits to Existing Douglas Installations _____	8b
Daylight Photocell & Motion Switching _____	9a
WRM-5104 & Power Cube Applications _____	9b

## PARTS & DIMENSIONS

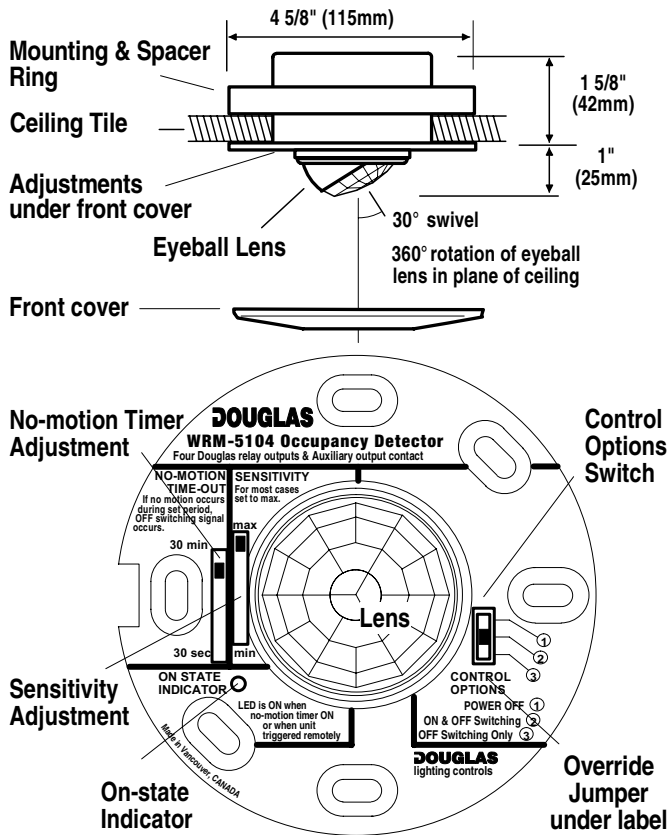

Page 1a

## SPECIFICATIONS FOR WRM-5104 OCCUPANCY DETECTOR

### GENERAL

- Power requirement: 20mA @ 24VAC or 24VDC
- Detection method: Passive Infra Red (PIR)
- Adjustable no-motion timer range: 30 seconds to 30 minutes
- Adjustable motion sensitivity

### OVERRIDE INPUTS

- The slave input is an override that causes the detector to switch connected relays on and off. This input permits extra detectors to be designated as slave detectors should coverage area need to be increased.
- The slave input can also be controlled with a contact to force the detector ON. This circuit can be used to provide a timed building wide override for institutional applications.

### OUTPUTS

- Four relay outputs compatible to all models of Douglas 2-wire relay. The outputs switch together as a group.
- Adjustable operation: OFF Only or ON & OFF.
- Auxiliary contact output (contact rating: 1A / 30V). Auxiliary contact unaffected by OFF Only option; contact always opens and closes.

## INSTALLATION GUIDE

The WRM-5104 occupancy detector is a versatile device that can be used in a variety of applications. For best results the following steps are recommended:

### 1) MOUNTING OF DETECTOR

Study pages 2a and 2b **carefully** before installing any conduit or wire. Conduit must be on the ends of mounting boxes. Use a deep box (2 inches) to provide enough space for the detector and the connection wires.

### 2) DETECTOR OPERATION

Pages 3a and 3b describe how an occupancy detector works and the function of the controls available on the WRM-5104 detector.

### 3) DETECTOR PLACEMENT

Pages 4a to 5b illustrate and describe placement issues. Carefully consider the placement of the detector. Coverage area, entrances, entrance paths and the activity that typically occurs in the room are all issues to consider when determining optimum detector placement.

### 4) ELECTRICAL CONNECTIONS

Pages 6a to 9b illustrate various schematics possible for the WRM-5104 occupancy detector. Select the appropriate circuit(s) for your application.

### 5) USE #18 AWG SOLID CONDUCTOR WIRE

The terminals of WRM-5104 detector are designed for #18 AWG SOLID conductor wire.

Page 1b

## START-UP and ADJUSTMENT

It is assumed that all connections are made, low voltage power is ON, the lamp being controlled is connected and functional and the circuit breaker is ON.

### 1) TEST THAT THE DETECTOR SWITCHES THE LIGHT(S)

The detector does not switch the light directly. The detector switches a relay, a power cube or signals another system.

To test if everything is working:

- Set the "Control Options" switch to the "POWER OFF" position.
- If lights are on, turn OFF the responsible relays by using an override switch or the manual lever built into the relay.  
(NOTE: Applications that use power cubes should automatically turn OFF when the detector is turned OFF).
- Turn the "Control Options" switch to the "ON & OFF Switching" position. The lights should turn ON almost right away (motion is not required). After 30 seconds, the lights should turn OFF.

### 2) ADJUSTING THE DETECTOR

To adjust the detector, the best time is right after the initial 30 second start-up described above. **For the next 180 seconds**, the detector will operate with a no-motion timer setting of 4 seconds. Use this quick response to test the detection. Align the lens if necessary and re-test. **After 180 seconds**, the detector will operate with the no-motion time set by the slider on the front (30 sec to 30 min).

### 3) TROUBLE SHOOTING

Check your wiring. Is the light bulb good? Is the line circuit from the relay to the lamp good and does it have power? Is the relay operating correctly? Is the connection from the detector to the relay correct and secure? Does the detector have 24V present? A careful, systematic check of these parts will usually identify the fault.

## **MOUNTING - OCTAGON BOX**

### **CONDUIT PLACEMENT**

WRM-5104 detector has a low, attractive profile when mounted on a ceiling. To accomplish this, all of the electronics and lens mechanism of the detector must fill the inside of the octagon box. Conduit **must** be attached at opposite ends of the box. Conduit attached at right angles to box will interfere with the detector case.

**Take care with positioning conduit to octagon box.**

### **MOUNTING HOLE POSITION**

WRM-5104 detector is well labeled to help users easily understand how to adjust the detector. The label covers 1 of the 2 pairs of mounting holes available for octagon box installations. The label is made of vinyl and can be peeled back to gain access to the hidden pair of mounting holes if needed. However, try to avoid this inconvenience and possibly damaging the label.

**Take care to position conduit with respect to the mounting screw's position.**

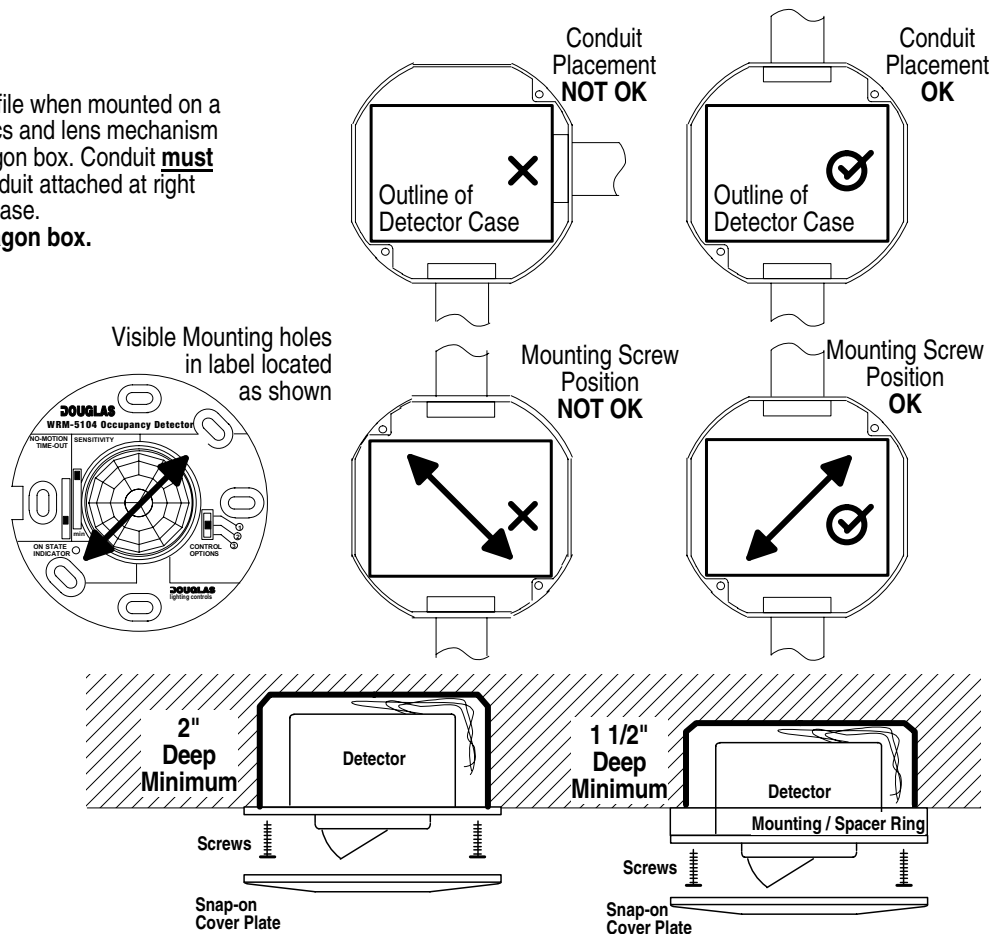

### **OCTAGON BOX DEPTH**

Use a deep octagon box (2" minimum). This will allow more space for wires. If the box is not deep enough, the Mounting / Spacer ring will help to provide more space at the expense of the low profile appearance.

## **MOUNTING - SINGLE GANG SIZE WALL BOX**

The WRM-5104 detector can also be mounted to single gang size wall boxes. Take care to use deep boxes.

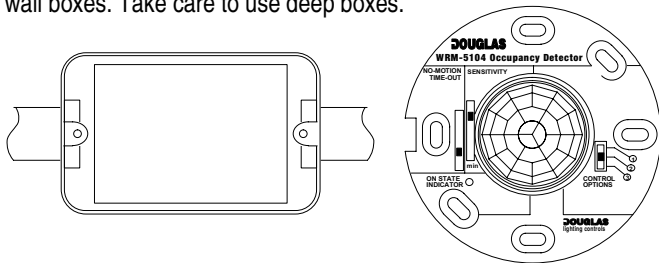

## **MOUNTING - PLASTER RING**

You must check to ensure that the opening of the plaster ring is large enough for the WRM-5104 detector. Many plaster rings have rounded corners which obstruct the detector from fitting thru the ring's opening.

## **MOUNTING - MOUNTING / SPACER RING**

The Mounting / Spacer Ring has 2 uses. It can be used as a spacer to allow the WRM-5104 to fit to shallow boxes or it can be used to mount the detector to ceiling tile. Check local fire regulations regarding ceiling tile installations. Most likely plenum-rated cable is necessary.

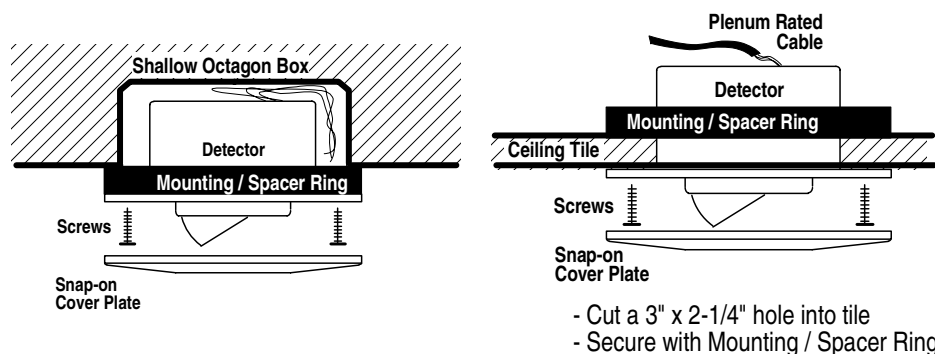

- Cut a 3" x 2-1/4" hole into tile
- Secure with Mounting / Spacer Ring

## SEQUENCE OF OPERATION

No-motion Timer built into detector

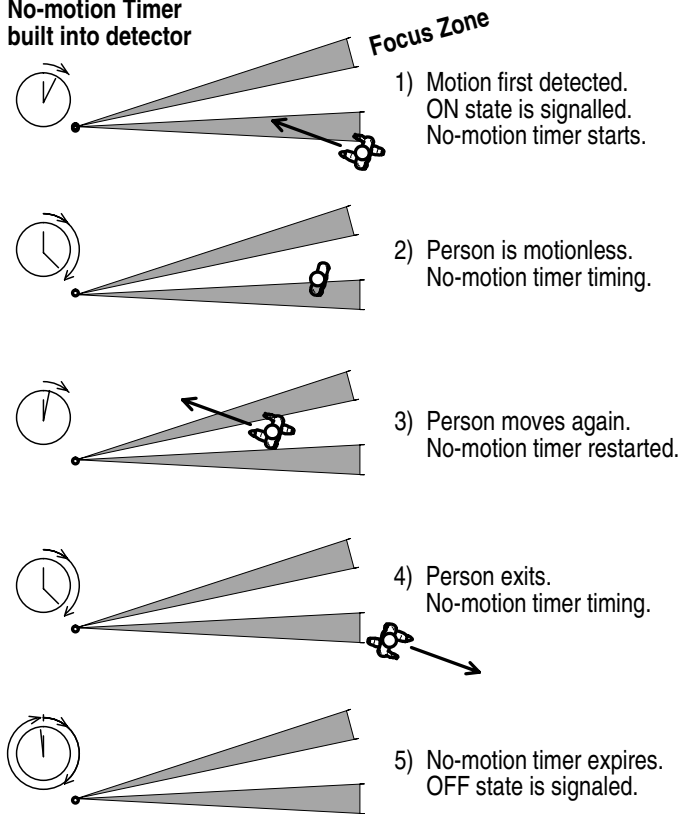

Page 3a

## NO-MOTION TIME-OUT

The no-motion timer used in the WRM-5104 detector is adjustable from 30 seconds to 30 minutes. Select the no-motion time that seems appropriate. In areas where walking traffic is common, a short time setting (less than 5 minutes) should give good results. In areas where sitting is the principal activity, a longer time would give better results (15 minutes or more).

If occupants are experiencing false OFF signals, increase the time setting. If there are no false OFF signals, try reducing the time setting. The lower the time setting, the more energy you will save.

## SENSITIVITY ADJUSTMENT

Set the sensitivity adjustment slider to maximum for most applications. In cases where hot air vents may cause false triggering, try reducing the sensitivity. If this does not work, then try re-aligning the lens to avoid false tripping signals.

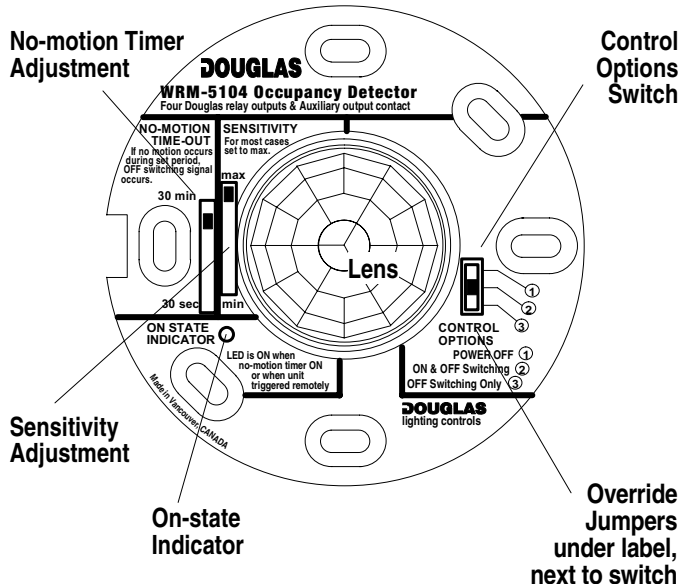

Page 3b

## CONTROL OPTIONS SWITCH

The detector can be set so that the relay output provides "ON & OFF Switching" or "OFF Switching Only". This is accomplished with the "Control Options" switch on the front of the unit (under cover plate).

In applications that have wall switches connected in parallel with the occupancy detector outputs, the "OFF Switching Only" option can be used. To the occupant, the switches are necessary for ON & OFF control and the detector is not noticed. The detector only ensures that lights are switched off after the room is vacated. This installation will have no false ON signals and the detector still provides the energy saving lights OFF function.

The "Control Options" switch can also be used to turn the detector's power off. When the detector is turned back on, it will follow the start-up sequence. See **START-UP AND ADJUSTMENT**.

The auxiliary contact always closes when motion is initially detected and always opens when the no-motion timer has expired. This is true even if the "Control Options" switch is in the "OFF Switching Only" position. The contact will open when the "Control Options" switch is set to the "POWER OFF" position.

## VERRIDE JUMPER

If a detector should fail, follow these procedures to turn ON the light. First turn the detector's power OFF ("Control Options" switch on front). Then turn the detector back on. If lights do not come ON, short the 2 prongs located under the label below the "Control Options" switch. If the light still does not come ON, it is likely that the fault is not with the detector and is elsewhere. In this case, check your wiring.

**METHOD OF DETECTION - PIR**

The WRM-5104 detector uses **Passive Infra Red (PIR)** technology. PIR occupancy detectors are optical devices that detect the infra-red energy emitted from all warm objects including people.

It is the **movement** of the infra-red source (walking or a handwave) that is "seen" by the detector. The detector accomplishes this by having several small lenses that each focus a zone onto a sensing element. As the warm object travels in to and out of a zone, the amount of infra-red light focused on the element changes. This is interpreted as motion.

Movements **across** a focus zone cause a stronger motion signal than movements **parallel** to a focus zone. When locating PIR occupancy detectors, try to maximize the probability of movements across the detection pattern.

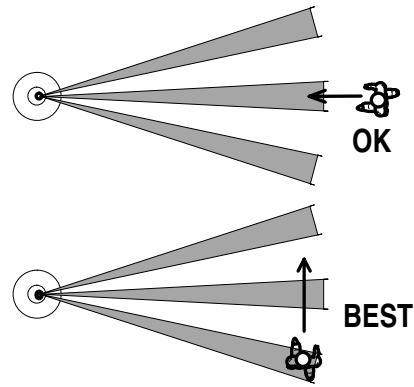

The amount of infra-red light focused on the sensing element is greater from objects that are close than from objects that are distant. Only at close range (less than 15') is handwave motion detectable. At greater distances (15' to 25') only walking motion is detectable.

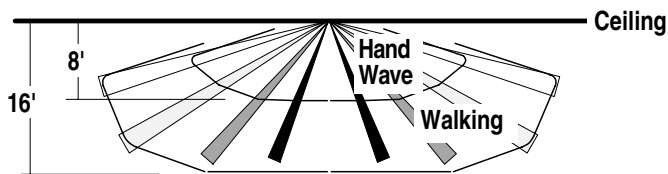
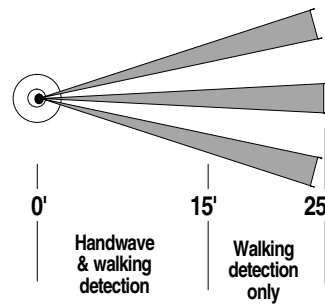

Side View

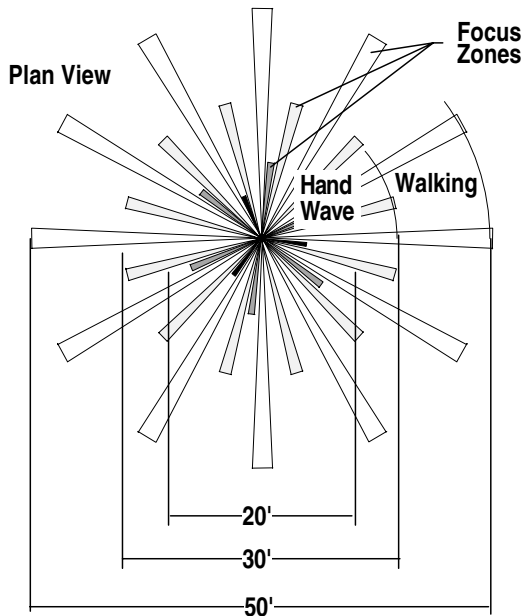

Plan View

**COVERAGE PATTERN**

The WRM-5104 detector is ceiling mounted and has the detection pattern shown at left. The pattern of the focus zones is shaped like the quills of a porcupine.

The ideal mounting height is between 8 and 12 feet. Detectors mounted above 12 feet will only be able to detect walking motion. Detectors mounted below 8 feet will have reduced coverage area.

If the activity in the room is primarily of a sitting nature and there is little traffic, then the handwave range should be used. In larger rooms several detectors may be required for proper coverage.

If the activity in the space includes regular walking motion, then the walking motion range can be used.

In rooms larger than 15' x 15' the best location is usually in the center of the room. In rooms smaller than 15' x 15' the best location is usually to one side of the room. In small rooms, try to position the detector so that focus zones do not point out entrances.

Handwave area

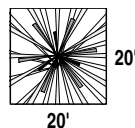

Small Rooms

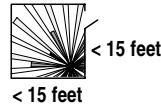

< 15 feet  
Locate detector in corner away from doorway.

Walking area

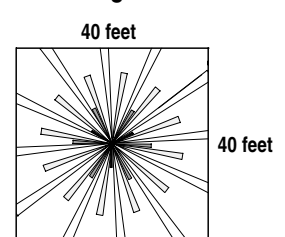

Large Rooms

Locate detector in center.

## COVERAGE PATTERN - APPLICATION TIPS

### WALKING MOTION

Rooms that only require detection of walking motion can be as large as 40'x40'.

For larger areas, install in a grid with 40' centers. In rooms such as classrooms (40x40 or less), one detector is often sufficient. Handwave motion is detected in the center area and walking motion is detected around the perimeter.

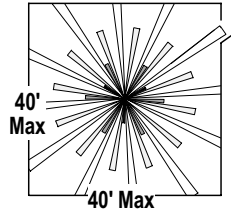

### HANDWAVE MOTION

Rooms that require detection of small movements (eg: hand wave), must be 20'x20' or less. For larger rooms or areas, install multiple detectors in a grid with 20' centers.

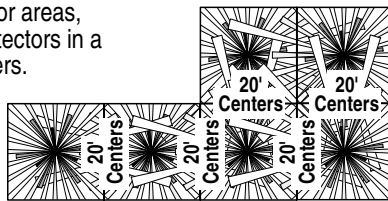
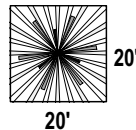

### HALLWAY MOTION

If using a WRM-5104 detector in a hallway application, it is recommended that the detectors be spaced no more than 30' apart. Since most traffic travels parallel to the focus zones, range of detection will be decreased.

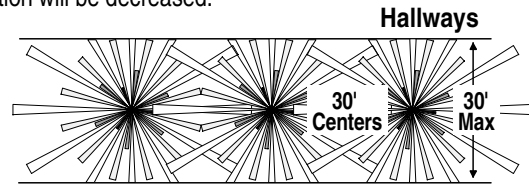

### SOLID OBJECTS

Detection cannot be made through solid objects such as partitions or bookshelves. Position detector(s) so that there are no obstructions.

### FORCED AIR VENTS

Locate detector away from forced air vents (4 feet or more). Large amounts of hot or cold moving air can be detected which causes false tripping. If this problem is occurring, try reducing the sensitivity. The swivel or rotation feature may also help reduce false tripping from air vents.

### OTHER MOVING OBJECTS

The WRM-5104 is tuned to detect human motion. Hanging objects (mobiles, balloons, etc.) should not cause false tripping. However, baseboard heaters with louvered blinds installed above can cause false tripping. The rising warm air heats and moves the louvers which can be falsely detected as human motion. The swivel feature may help eliminate this problem. If the room has wall switches connected in parallel, the "OFF Switching Only" control option can be selected to prevent false ON tripping.

Page 5a

## ALIGNMENT OF FOCUS ZONES

### WHAT TO ALIGN?

Rotation and swivel alignment aim the focus zones of the detector at specific points such as doorways. The focus zones of the lens radiate straight out from the flat areas on the lens. Use the lens flats to give some indication of where you are aiming.

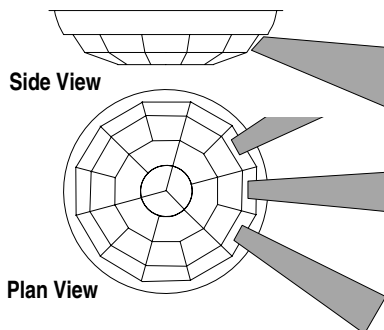

### SWIVEL ALIGNMENT

Swivel alignment will not increase the range of detection. Examine the geometry of the coverage pattern (page 4b) and imagine it being swiveled. Notice that the range does not increase in the direction the lens is swiveled to. Instead, the range stays about the same.

If a focus zone is aimed at an entrance that is open to a hallway (1), traffic passing by could be detected. To prevent this, use the swivel feature to point the focus zone at the floor of the door (2).

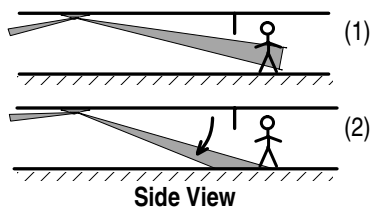

Some rooms may have sloped ceilings. Use the swivel feature to level the detection pattern with the floor (3).

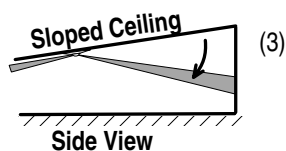

### ROTATION ALIGNMENT

It is possible for a person to walk straight towards a PIR detector without being detected for some distance. This can occur at the extreme of the unit's range (15 to 25 feet away) where there is a large enough space in between two of the zones.

The lens of the WRM-5104 can be rotated so that the focus zone can be aimed into oncoming traffic.

The rotation feature is often needed in larger rooms (greater than 20' x 20') that have an entrance path straight at the detector. To prevent the occupant from having to travel a distance into the room before an ON signal results, rotate the lens to aim a zone directly at the entrance.

In narrow hallways, the rotation feature may also improve detection results.

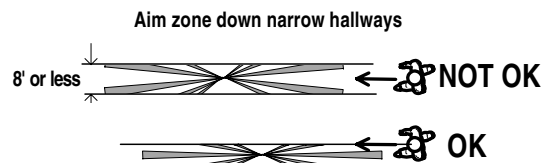
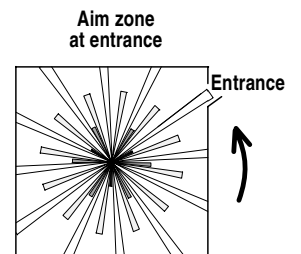
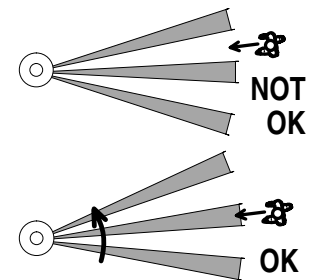

Page 5b

## ELECTRICAL CONNECTIONS

### GENERAL INFORMATION

The WRM-5104 detector has several inputs and outputs. Your application may use some or all of the inputs and outputs. The following pages show various common schematics that should provide solutions for most applications.

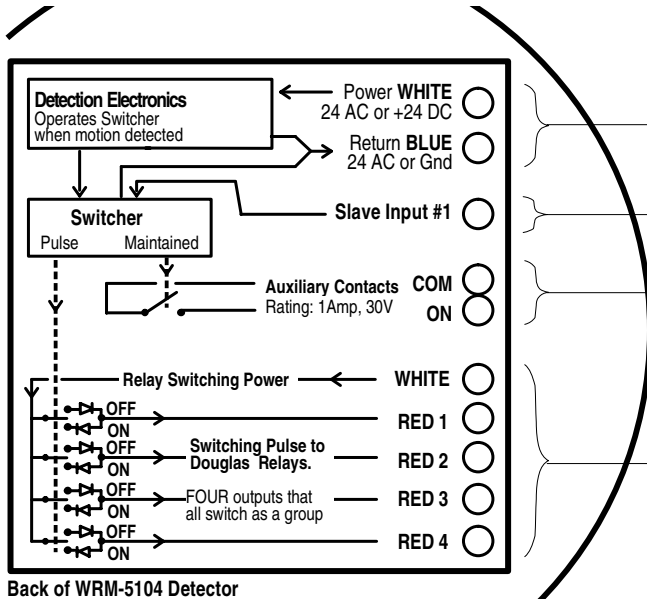

### MOTION DETECTOR POWER

The WRM-5104 detector requires 24VAC (or 24VDC) for power. The unit uses 20mA of current to operate. Power used to switch relays is additional.

### SLAVE INPUT

Applying the WHITE (24VAC or +24VDC) Power to this terminal forces the unit into the ON state. This input is used when multiple detectors are used for a large area.

### AUXILIARY OUTPUT CONTACT

The auxiliary contact is rated at 30Volts - 1Amp. It has 2 common uses:

- 1) (If the detector is a slave detector) To signal the master detector's slave input.
- 2) To signal power cubes or other devices.

### DOUGLAS RELAY OUTPUT

The WRM-5104 detector can switch all models of Douglas 20 Amp, 120/277/347 VAC latching 2-wire relays. There are 4 isolated outputs that switch together.

## WIRE SIZE AND TYPE - IMPORTANT

The terminals of the WRM-5104 detector are designed for #18 AWG SOLID conductors.

### **DO NOT USE HEAVIER GAUGES.**

Wires heavier than #18 will damage the connector and will prevent the detector from fitting properly into a backbox.

The WRM-5104 uses quick connect terminals for the circuits that switch the Douglas relays. These terminals are designed for #18 AWG SOLID conductors. Strip the wire and insert it into the terminal's hole. To remove, press the orange release tab. Do not attempt to insert more than 1 wire into a quick connect terminal.

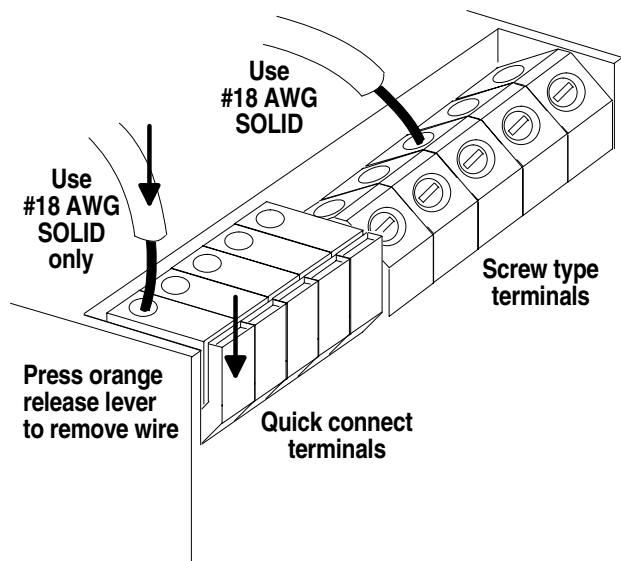

## SWITCHING DOUGLAS 2-WIRE RELAYS

The WRM-5104 has 4 outputs that switch Douglas 2-Wire relays. The 4 outputs of the detector switch together.

Wall switches can be connected in parallel with each of the relay outputs to provide occupant control of individual lighting circuits. Occupant control of lights is usually necessary in boardroom and classroom applications to facilitate presentations.

### "OFF SWITCHING ONLY" CONTROL OPTION

Applications that have wall switches installed can take advantage of the "OFF Switching Only" control option of the WRM-5104 detector. Only when the room becomes unoccupied does the detector switch the lights OFF. Occupants use the switches for usual ON & OFF control.

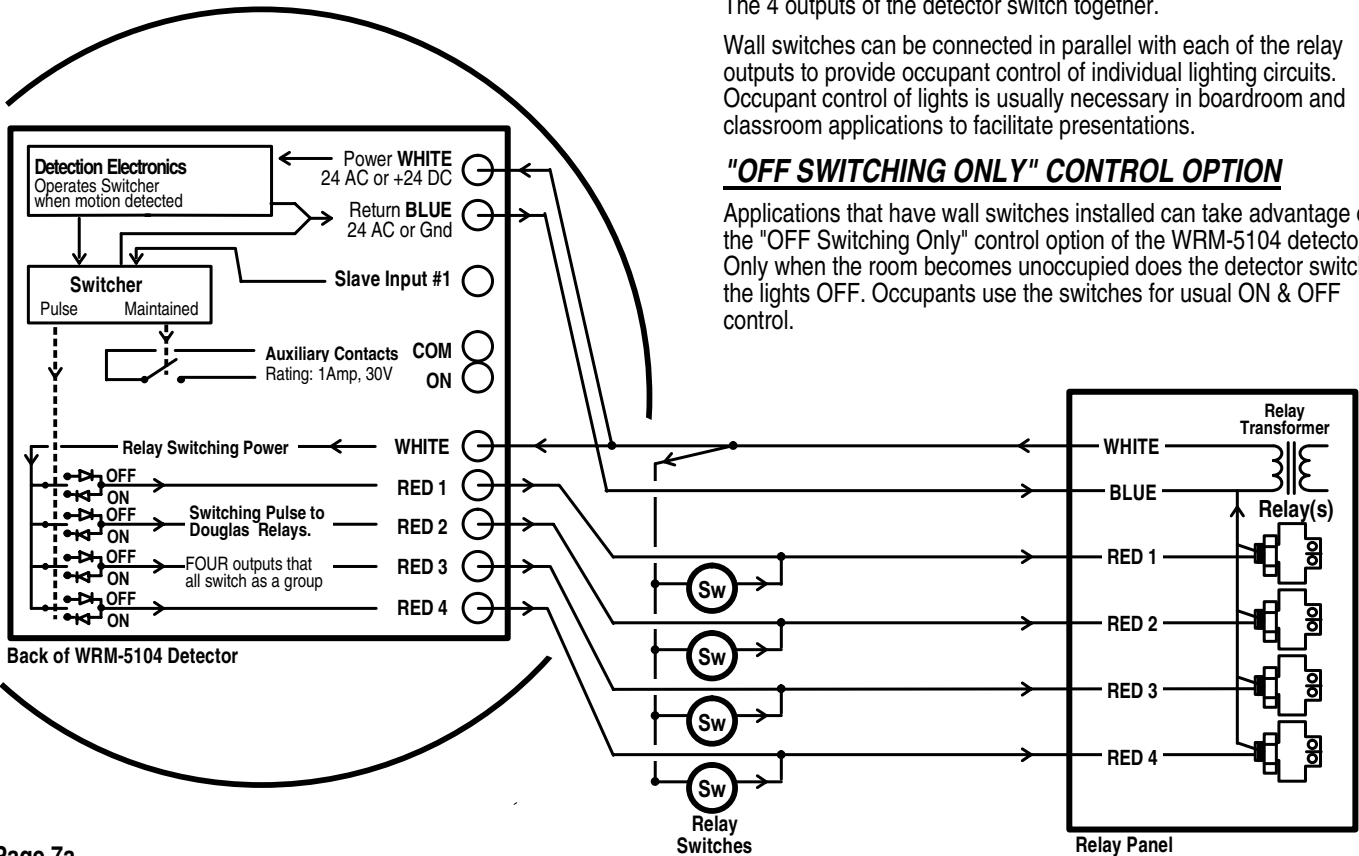

Page 7a

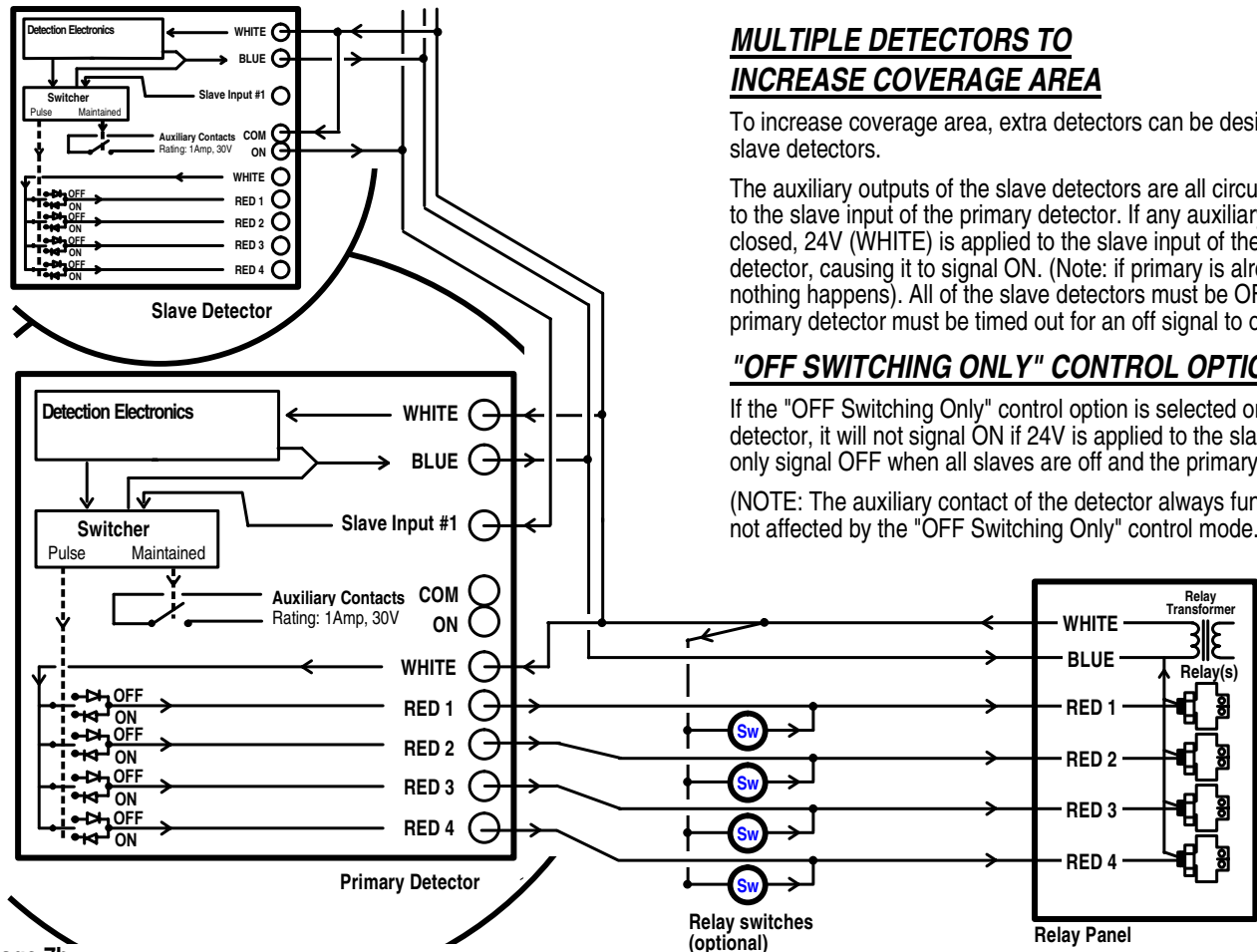

### MULTIPLE DETECTORS TO INCREASE COVERAGE AREA

To increase coverage area, extra detectors can be designated as slave detectors.

The auxiliary outputs of the slave detectors are all circuited in parallel to the slave input of the primary detector. If any auxiliary output is closed, 24V (WHITE) is applied to the slave input of the primary detector, causing it to signal ON. (Note: if primary is already ON, nothing happens). All of the slave detectors must be OFF and the primary detector must be timed out for an off signal to occur.

### "OFF SWITCHING ONLY" CONTROL OPTION

If the "OFF Switching Only" control option is selected on the primary detector, it will not signal ON if 24V is applied to the slave input. It will only signal OFF when all slaves are off and the primary has timed out.

(NOTE: The auxiliary contact of the detector always functions and is not affected by the "OFF Switching Only" control mode.)

Page 7b

## BUILDING WIDE OVERRIDE WITH TIMER

In some institutional applications it may be desirable to be able to force all of the detectors ON for certain periods of the day. Consider the corridors of a health care facility. During working hours (day time) it is desirable to have lights ON at all times. During the quiet hours (evening and night) it is preferable to switch the lights with the occupancy and/or light detectors.

The Building Wide Override is accomplished by wiring a contact to all of the slave input terminals of the detectors. The 24V power (WHITE) is used to signal the detectors ON. If they are already ON, nothing happens; if they are OFF, they switch ON. When the 24V is removed, the detectors switch relays OFF **unless** the room is occupied and the detectors are ON by virtue of the motion detection. This ensures a smooth transition from ON mode to Occupancy mode.

In cases where there are slave detectors connected to the slave input of a primary detector, connect the 24V (WHITE) to the slave input of one of the slave detectors. This causes the slave detector to switch ON, which in turn signals the primary detector to switch ON (Schematic not shown).

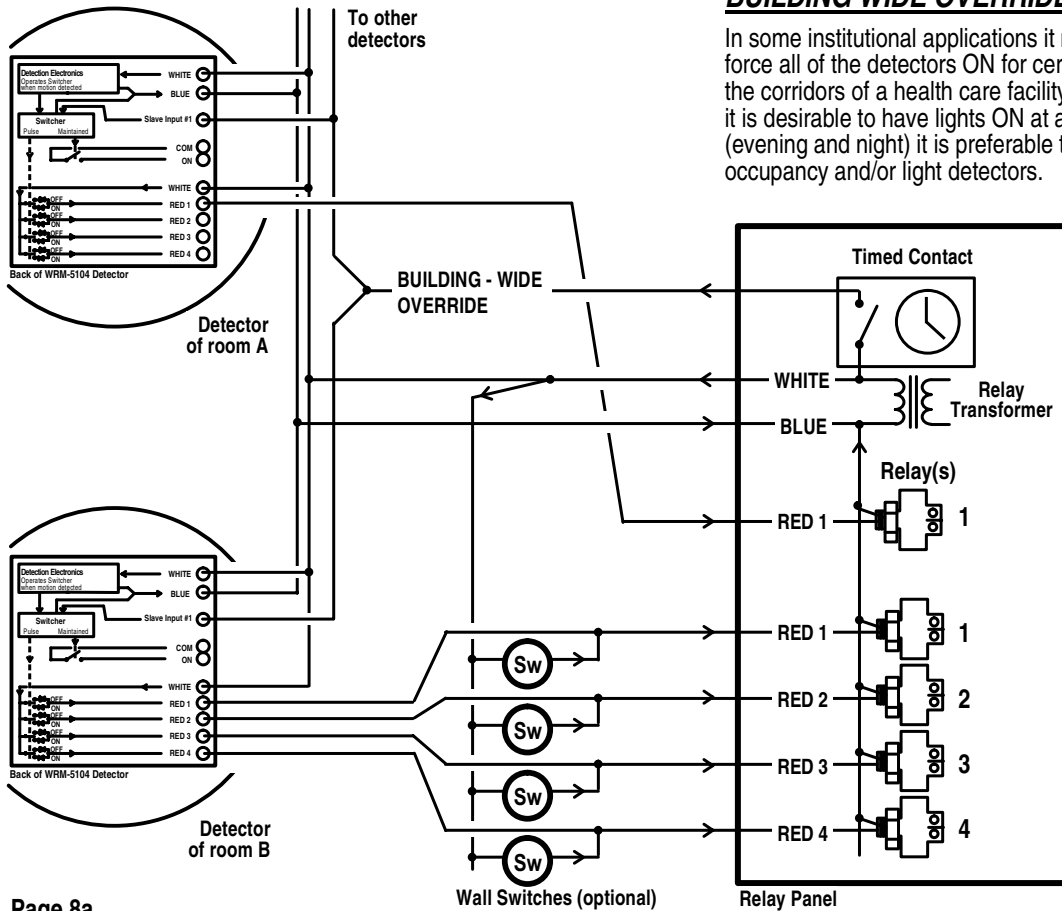

Page 8a

## RETROFITS TO EXISTING INSTALLATIONS

To retrofit detectors into existing Douglas installations, connect the detector's relay output (WHITE & RED) in parallel to the switch(es) already installed in the room.

The detector requires 24V to operate. The 24V may not be available in the room due to the lack of one wire - the blue return wire.

If this is the case and it proves impractical to bring another wire from the relay panel, install a transformer local to the detector for power. The transformer can be shared between several detectors located near each other.

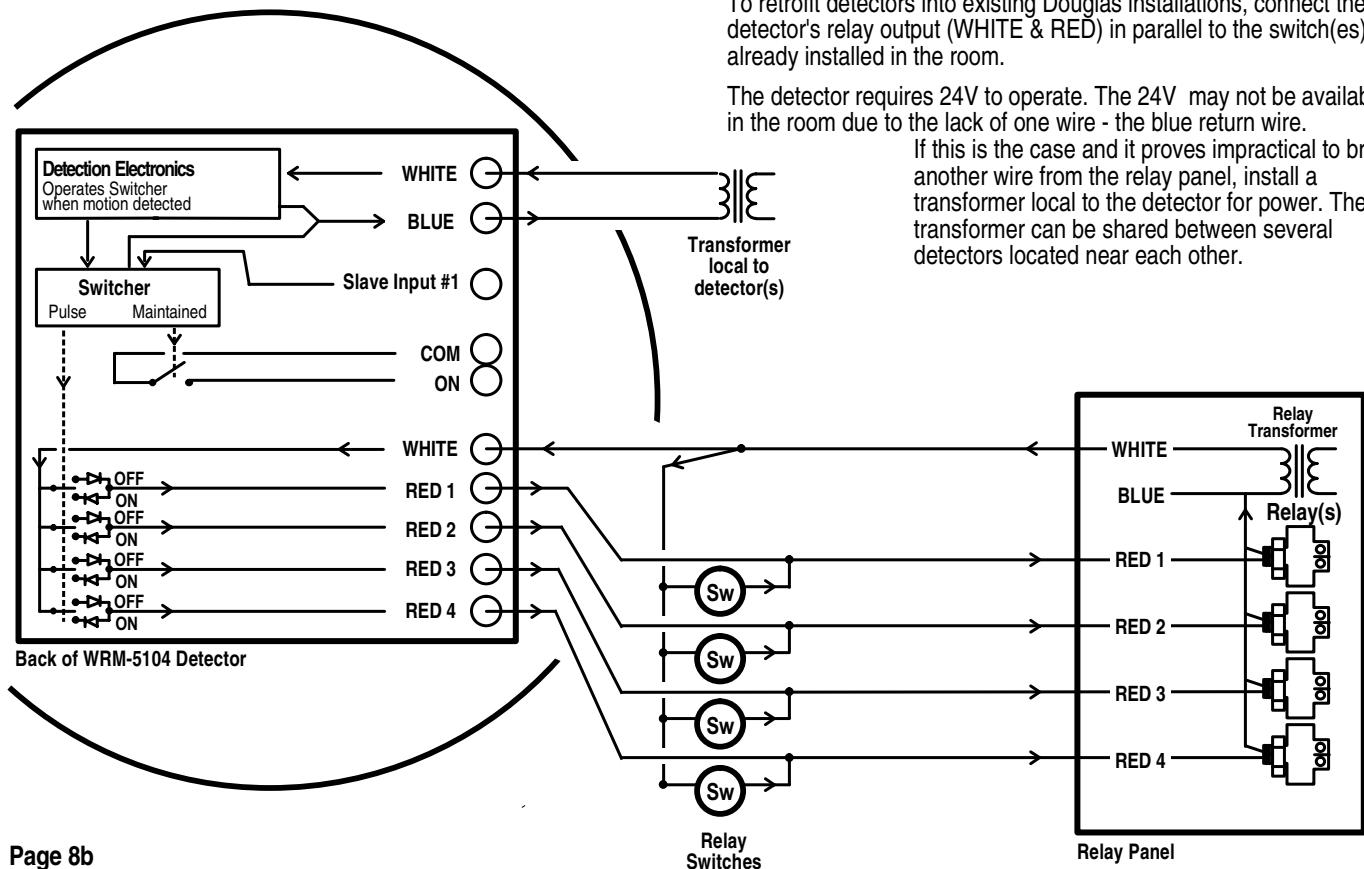

Page 8b



# **DOUGLAS** **lighting controls®**

www.DouglasLightingControls.com  
4455 Juneau Street • Burnaby, B.C. • CANADA  
phone: (604) 873-2797 • fax: (604) 873-6939

## ***WARRANTY***

DOUGLAS products are warranted for one year from the date of purchase by the consumer against defects due to materials and the company's workmanship only. The sole obligation hereunder shall be to repair, or at the company's option to replace, products as aforesaid, provided same are returned, upon authorization, 'Transportation Prepaid' to the company's Burnaby, CANADA office within the said period. Defects or failures due to improper or careless installation, storage or handling, or usage other than rated conditions, are specifically excluded from this warranty. No liability is accepted for return transportation charges following repair or replacement as aforesaid or for reinstallation costs. No other liability of any nature or kind, whether arising out of or from the use of the product, whether or not defective, is assumed.

DOUGLAS lighting controls reserves the right to cancel or change items shown in this publication without notice.