

**INTRODUCTION TO
LOW VOLTAGE RELAY CONTROL**

A low voltage lighting control system uses a relay to switch the lighting load. The relay replaces the line voltage switches.

Relays permit light gauge, low voltage control wiring (#18 AWG) to control heavy gauge, higher voltage branch circuits.

There are 2 general types of relays; electrically held and latching. The electrically held relay permits control from a remote location however it cannot adequately provide multiple control features.

A latching type relay is well suited to branch circuit control for it can support advanced control features. Latching relays are operated with an electrical pulse. The relay "remembers" the last electrical command by latching ON or OFF.

The big advantage of latching, pulse activated relays is that several different switch devices can be connected to it at the same time with simple wiring. This advantage allows great flexibility for ON/OFF lighting control applications.

A relay controlled by a pulse (latching type relay), requires control power only when being switched. At any given moment, the amount of power required for a system of relays is small. Thus, one transformer power supply can service many Douglas latching relays.

Controlling a branch circuit with a line voltage switch

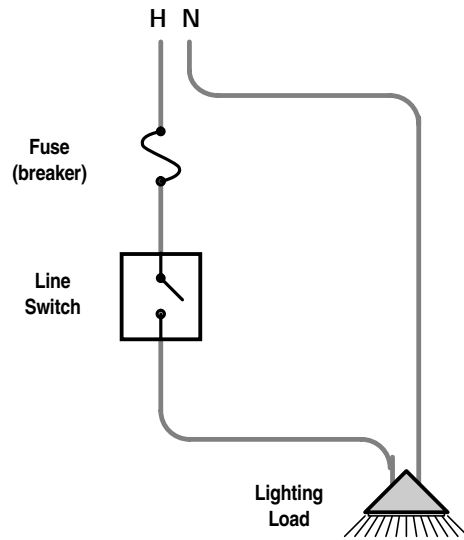

Controlling a branch circuit with a latching relay

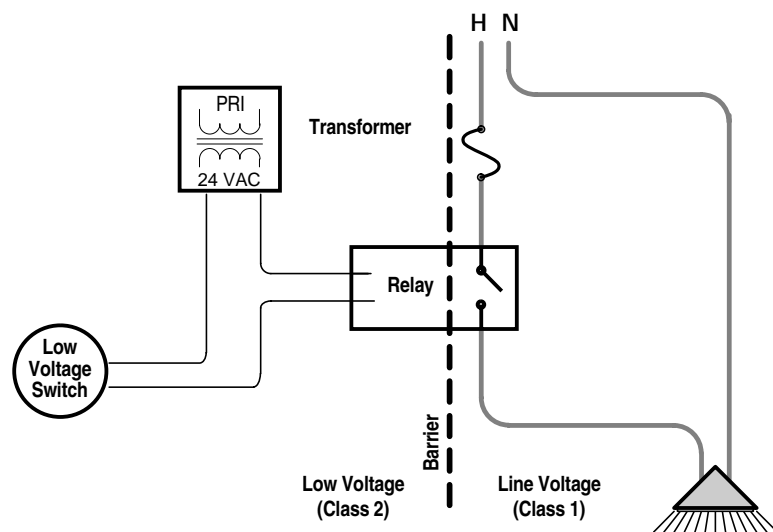

**Latching
Relays can be
controlled by
many different
low voltage
control
devices**

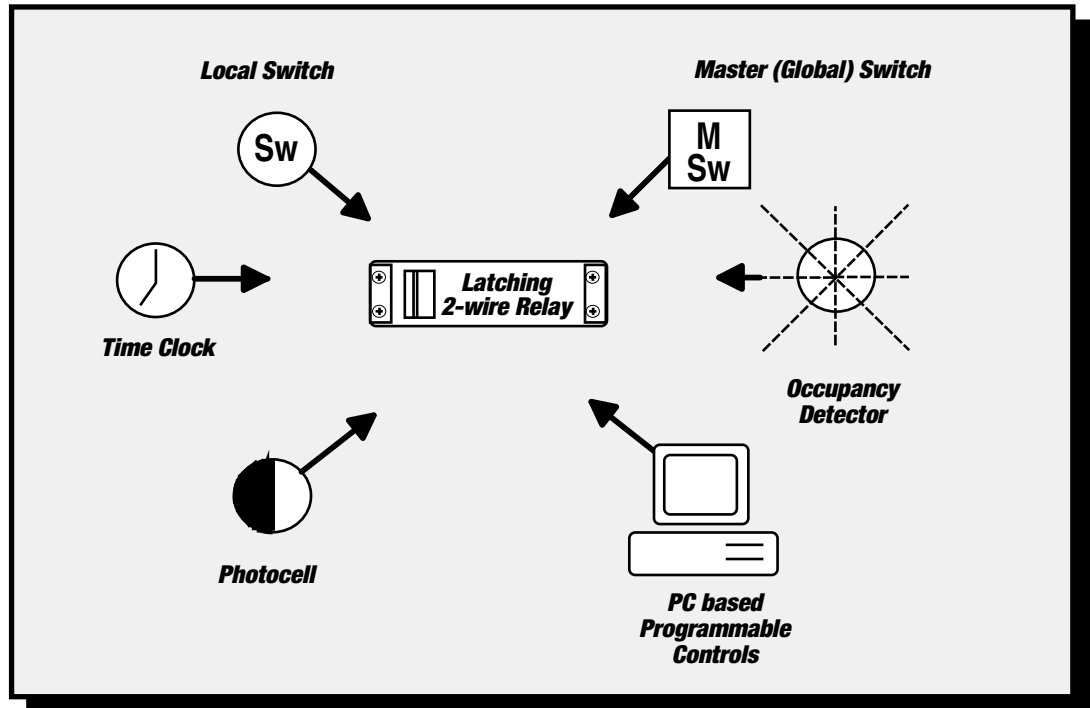

LATCHING RELAYS ARE IDEAL FOR:

Long Wire Runs

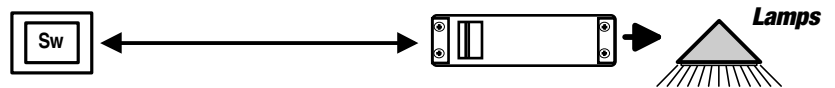

Multiple Location Switching

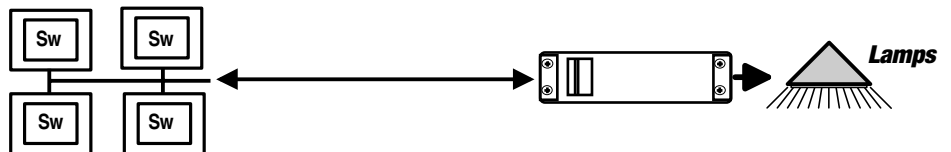

Controlling Large Loads

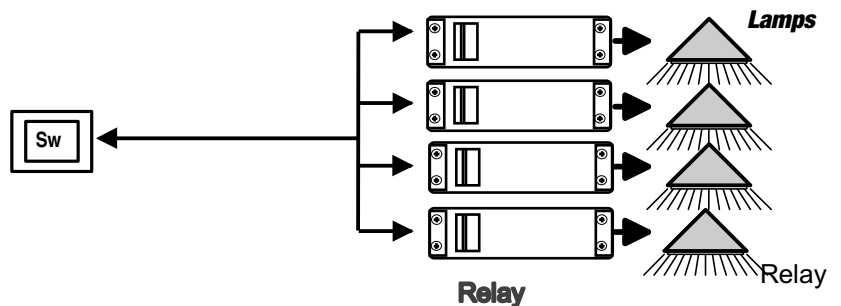

LOW VOLTAGE SWITCHING

Except when issuing a pulse, a low voltage switch is dormant. Each switch "takes control" only when it issues a pulse. Therefore several switch devices can control the same relay without interfering with each other.

A low voltage switch is not necessarily a wall switch. It can also be an electronically controlled device such as a time clock, occupancy detector, relay scanner or interface computers.

Regardless of which switch device is used or how many switching devices are connected to a particular relay, the rule "Last Switch Used Wins" applies. For example, a relay scanner turns off the relay at day's end and the local switch permits an occupant to turn the relay back on.

There are several ways to provide low voltage switching:

- wall switches
- relay scanners
- interface computers
- time clocks
- occupancy detectors
- photocell controls
- building management systems

Wall Switches

Wall switches are designed so that they can provide an ON or OFF pulse to the relay. Switches may also have indicator/locator lights. A red LED is used for indication (ON) and a green LED is used for location (OFF) . A keyed version is also available.

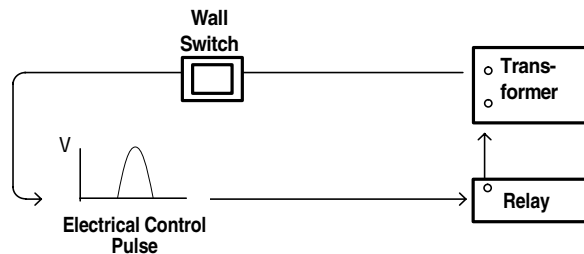
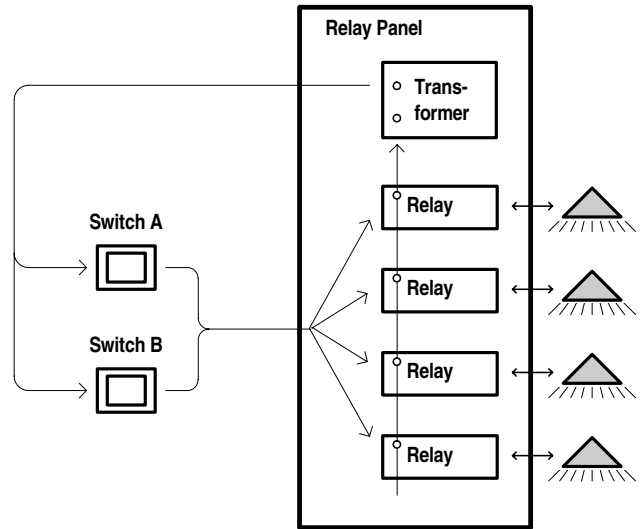
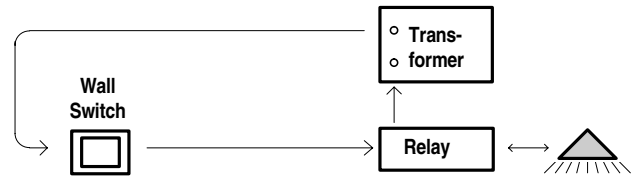

DOUGLAS SWITCH CAPACITIES

Two standard low voltage switches are available:

- WR-8001 Rocker switch
3 Amp rating, 8 relays maximum.
- WR-8501 LED switch
1.5 Amp rating, 4 relays maximum

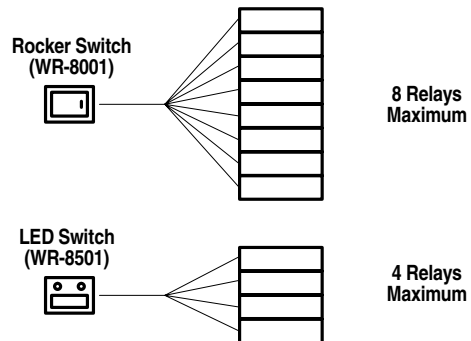

RELAY SCANNERS

Relay scanners are electronic devices that permit switching control of a group of relays with a master switch, while allowing each relay in the group to be controlled by an individual local switch.

Relay scanners also permit relay control by auxiliary devices such as timers, photocells, or building automation systems (BAS).

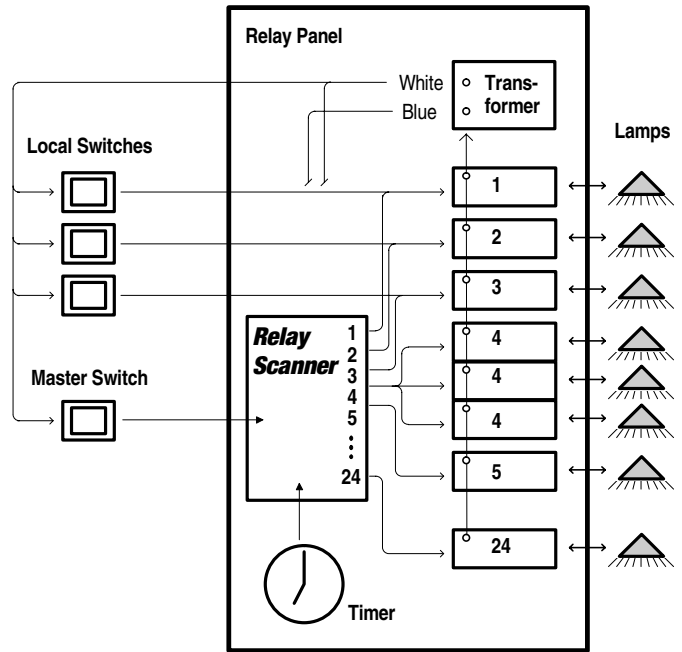

PROGRAMMABLE RELAY SCANNERS

Programmable relay scanners add to the basic relay scanner the ability to divide the connected relays into 5 master switch groups.

Since each group must operate independently from other groups and be controlled by a switch (or time clock, etc) this device will reduce the need for multiple relay scanners. Each master switch will provide "ON" status if one or more relays in a programmed group is ON.

Each master switch input can be programmed to issue a "flick" warn to occupants prior to an OFF sweep by a time clock.

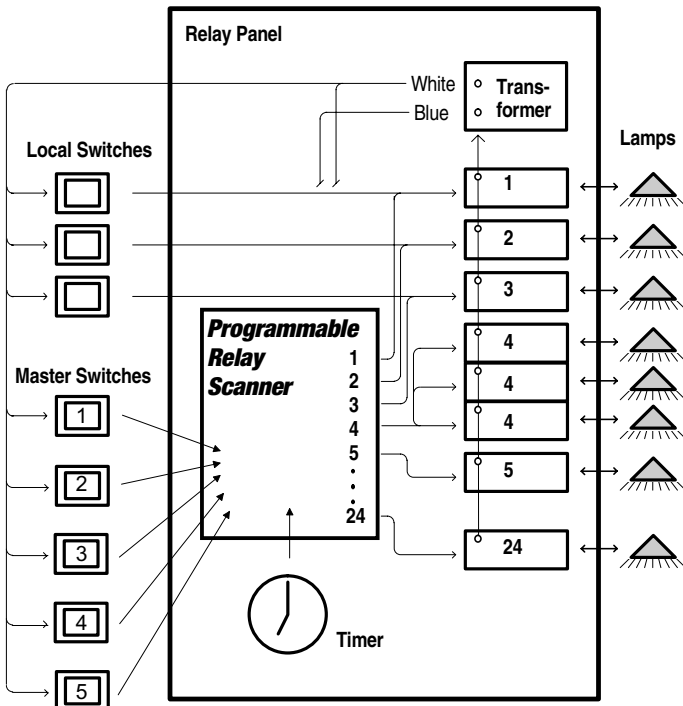

**MULTIPLE PANEL CONTROL
USING RELAY SCANNERS**

Control spanning several relay panels is often a requirement. To ensure safety and proper application, electrical codes require that the low voltage relays powered by different transformers be electrically isolated from each other.

Relay scanners provide electrical isolation between the master switch and the relay panel's circuit. Thus the master switch (or timer) circuit can be connected to several panels and isolation between panels is assured.

**Multi-panel,
Multi-relay
Switching**

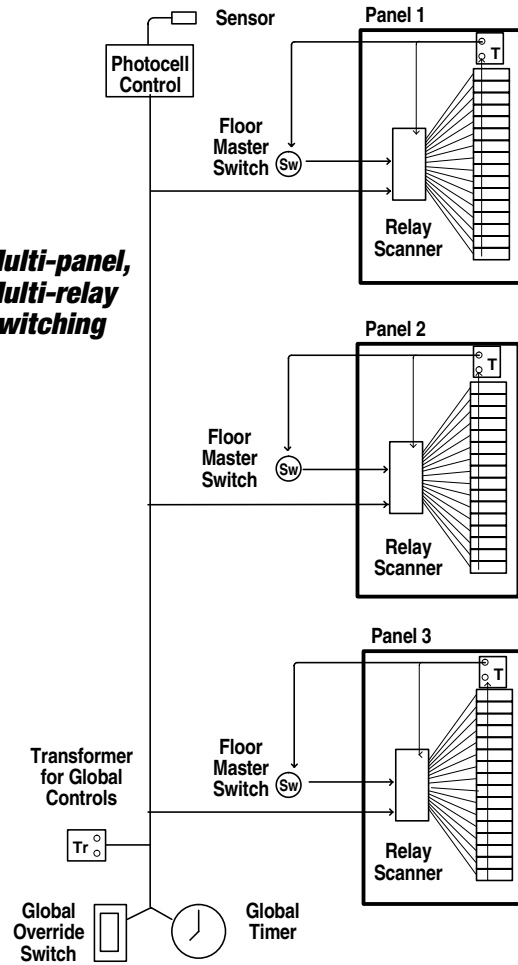

SAMPLE COMMERCIAL APPLICATION

In the example illustrated, each floor has a relay scanner mounted in the relay panel. Individual rooms have local switches that permit occupants to turn individual lights ON or OFF as desired. Each floor can have a floor master switch(es) that permits the last person leaving to turn OFF all lights of the floor.

The building timer is connected to the auxiliary inputs of all the scanners. The timer is set to turn all lights OFF at 6 PM and then provide repeated OFF sweeps every two hours throughout the evening.

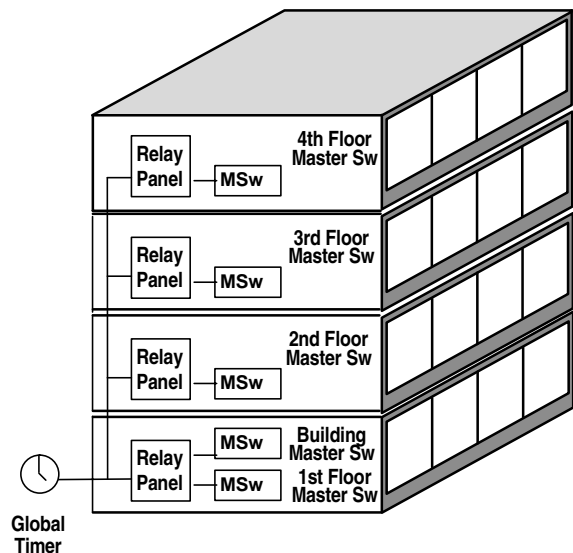

PROGRAMMABLE INTERFACE COMPUTERS

Interface computers are relay scanners with enough intelligence to time control each connected relay and provide programmable inputs for switches.

Relay panels containing interface computers may be "stand alone" or "networked." The decision on which method to use depends on the switching arrangement. If relays from different panels are to be operated from a single switch, then a networked system will be required.

Similarly if there are many panels, a networked system would be preferred as it will be much easier to program using a central PC instead of the panel-by-panel programming required by stand alone systems.

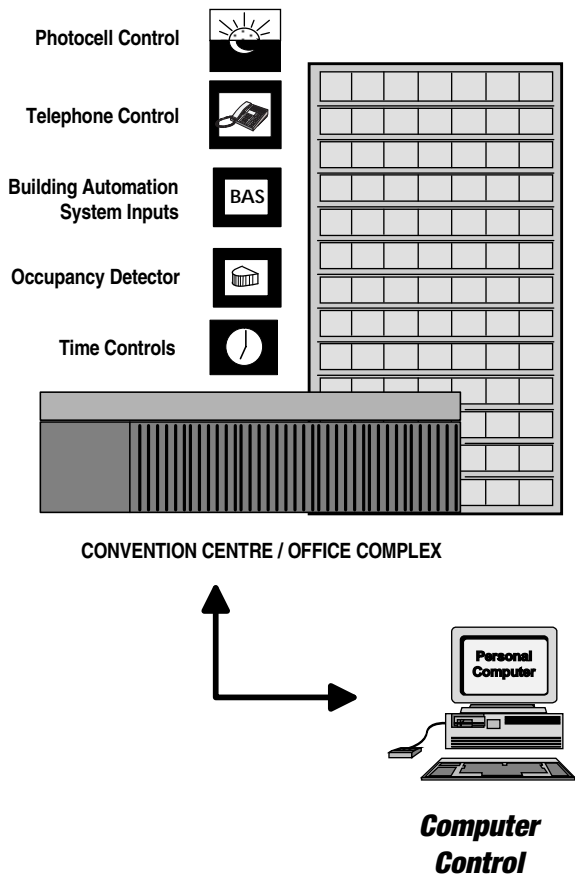
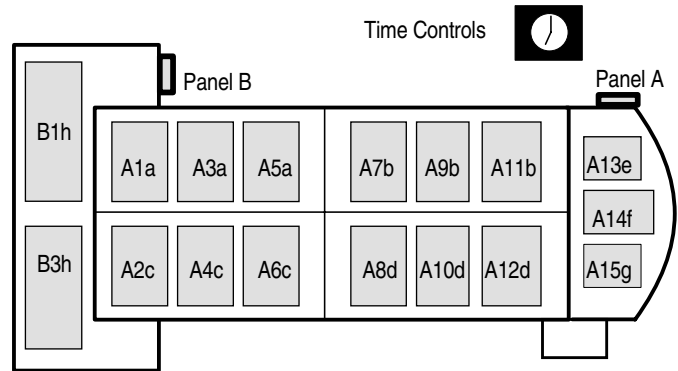

MULTIPLE PANEL CONTROL USING A NETWORK

Programmable control features are available by connecting Douglas interface computers to Douglas relays. Complete networked control systems of multiple relay panels can be controlled by connecting the relay panel's interface computers together via a dataline.

Switches may be programmed to operate any or all relays in the system. Numerous software features are available to provide sophisticated control and reporting features.

Standard software features allow relay groups, timed based scheduling, global switching functions, flick warn and repeat off sweeps.

Optional features include custom graphic screen interface, tenant logging, telephone interface, and an interface with Dilor Architectural Dimming Systems controls.

**MULTIPLE PANEL CONTROL
USING A NETWORKED LIGHTING
CONTROL SYSTEM**

Programmable Interface Computer Features

- Control relay groups
- Programmable time based schedules
- Master Switch Functions
- Flick warning & repeat OFF sweeps

Networked System's Features

- Control multi-panel, large relay groups
- Custom graphic screen interface
- Tenant logging
- Telephone interface
- Local and global switch functions
- Control of ALCII Architectural Dimming Systems
(See Dilor Architectural Dimmer's Catalog)

The lighting control system operates even if the PC is not on line. All schedules and groups are retained in non-volatile memory.

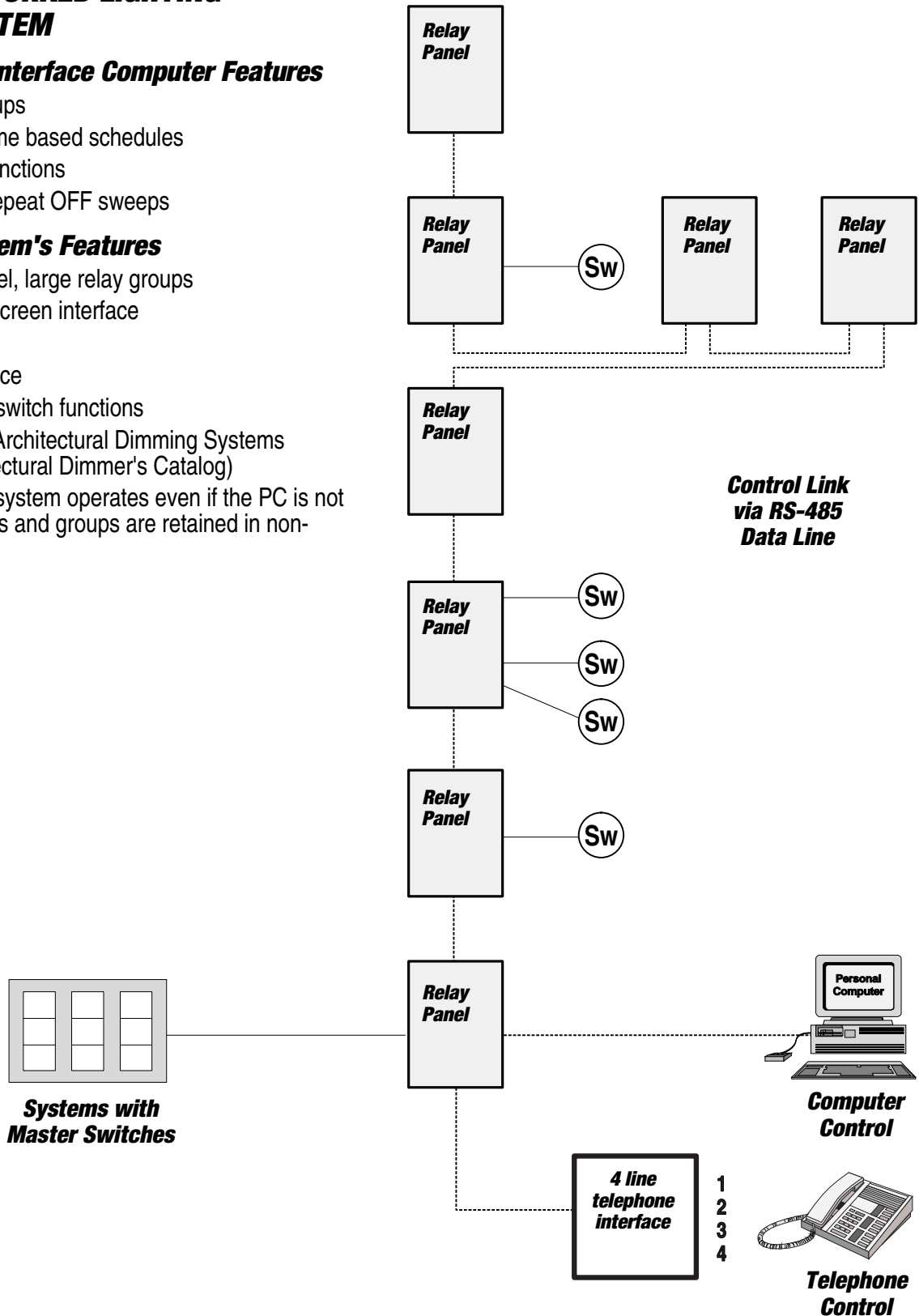

ESTABLISH REQUIREMENTS

The Douglas family of low voltage products are designed to be very adaptable and flexible, however, some initial planning will yield the best results.

The lighting control requirements of most projects are to achieve energy savings and owner convenience. If economy is the main requirement, then the objective is to turn lights off while allowing occupants local override capability. If convenience is the main requirement, then the objective is to provide the occupants with special control features that make it easy to control the building from a single location.

Once the general control requirements have been defined for the project, design can proceed with laying out the system. The best method for designing and describing the system are a reflected ceiling plan, a one-line diagram and a relay schedule. This will help clarify the control requirements, the routing, location and operation of the line voltage circuits, relay panels and low voltage control circuits.

Commercial Example:

A convention center has applications for economy and convenience. Economy is the focus in the office and exterior areas while convenience is the central issue in the main convention hall area. A breakdown of the desired results could be:

Office areas (Economy)

- Sweep all lights OFF at 6 PM.
- Repeat OFF sweeps at 9, 12 PM and 2 AM.
- Override capability of each local area by either a room or local area switch.
- If 2 level lighting is used, then features such as 1 level OFF sweep at 12 noon by timer or 1 level OFF sweep by photocell signal can provide more energy savings.

Exterior areas (Economy & Convenience)

- At dusk sweep lights ON by photocell signal.
- At 12 AM sweep some lights OFF by timer.
- At 6 AM sweep lights back ON.
- At dawn sweep all lights OFF by photocell signal.

Common interiors (Economy)

- Turn circuits OFF in areas not being used by occupants by occupancy detectors.

Convention hall & access areas

- If the main hall is divided into smaller halls, then switch stations located in the smaller halls can be locked so that the main hall switching is inoperable and the switching for the smaller area is operable.
- Access areas to the hall(s) will often require multi-circuit control. Lights can be easily turned ON to host a event and just as easily turned OFF when the event is over.
- Provide all OFF sweep at 4 AM to turn lights OFF left on by previous event. The 4 AM OFF sweep time is unlikely to conflict with a event.

Residential Example:

For a residence the purpose is mostly convenience. Features such as control of a circuit(s) from several locations and local/master switching are most often desired.

Multi-way control (Convenience)

- Often it is desirable to control the same circuits from several locations such as the kitchen, front entrance and master bedroom.

Exterior areas

- Lighting for landscaping, driveway or detached buildings (such as a garage or barn) can be controlled from a central spot.

Common areas (Convenience & Economy)

- The common areas of a house, such as the living, kitchen and hallway areas, can be controlled by a single master switch. This permits easy control of all lights ON or OFF from entrance way and from master bedroom (there are often upwards of 50 circuits in the common areas of a larger home).

Security feature (Security)

- If master ON/OFF control exists and a security system is present, it is simple to connect the two together so that on breach of security, all lights come ON. Additionally, a timer can turn lights ON and OFF while occupants are away to keep the home looking "lived-in".

CIRCUIT DESIGN & LAYOUT

Since installation of line voltage wiring is more costly and awkward than low voltage wiring, it should be considered first. The wiring of line voltage always follows the same sequence: circuit breaker - relay - lighting load. A circuit breaker may service more than one relay when loads are small. Thus several wire runs could exist for a given breaker circuit.

Often the simplest and best approach is to locate the relay panel beside the breaker panel. Circuits feed from the breaker panel to the relay panel and then off to the loads.

In some cases it is more economical from a installation and materials perspective to locate the relay panel closer to the loads. The main circuit(s) go from the breaker panel to the remote relay panel and then distribute to the local loads. (Caution; relays make an audible "click" when switched; take care to locate panels where the "click" will not irritate occupants). The routing of circuits and location of panels is often best done by marking up the reflected ceiling plan.

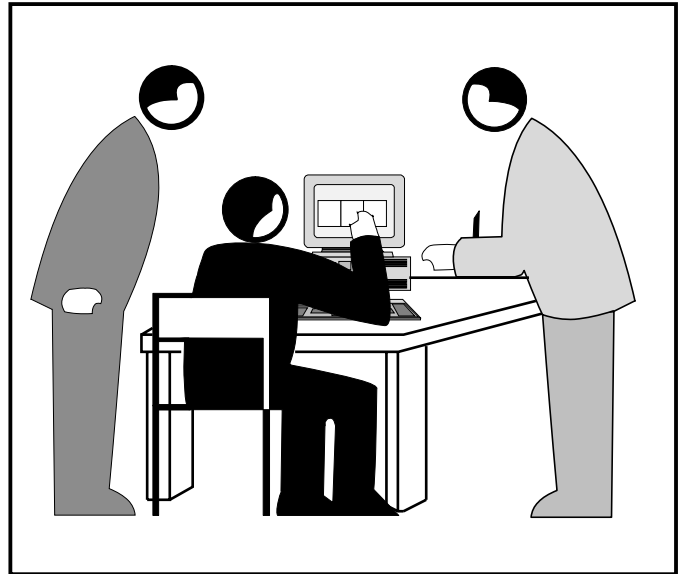

LOCAL SWITCH LOCATIONS & FUNCTION

After the line voltage circuiting has been determined the low voltage controls can be considered in detail. Switch locations are often noted with the low voltage switch symbol followed by a lower case letter. The fixture(s) to be controlled are labeled with the appropriate switch letter. If the line circuit numbers are known, apply the letter as a suffix to the circuit number.

Local & Master Switch Locations

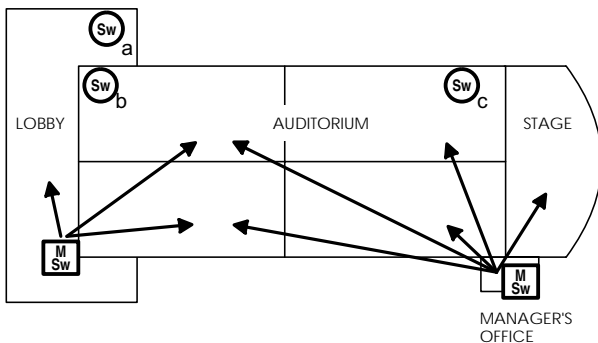

MASTER SWITCH LOCATIONS & FUNCTIONS

While the reflected ceiling plan is being completed, consider the master control requirements by listing their intended function on the plan. If there are 2 or more master controls controlling one circuit it is advisable to make a relay schedule.

Once the reflected plan has been considered in detail and is complete, a good approach is to update the one line diagram with the relay totals and information about the master switching. This will summarize the requirements and determine the devices and circuiting required for the low voltage system.

The **One Line Diagram** assists the contractor in determining wire runs and connection details when multiple relay panels are involved.

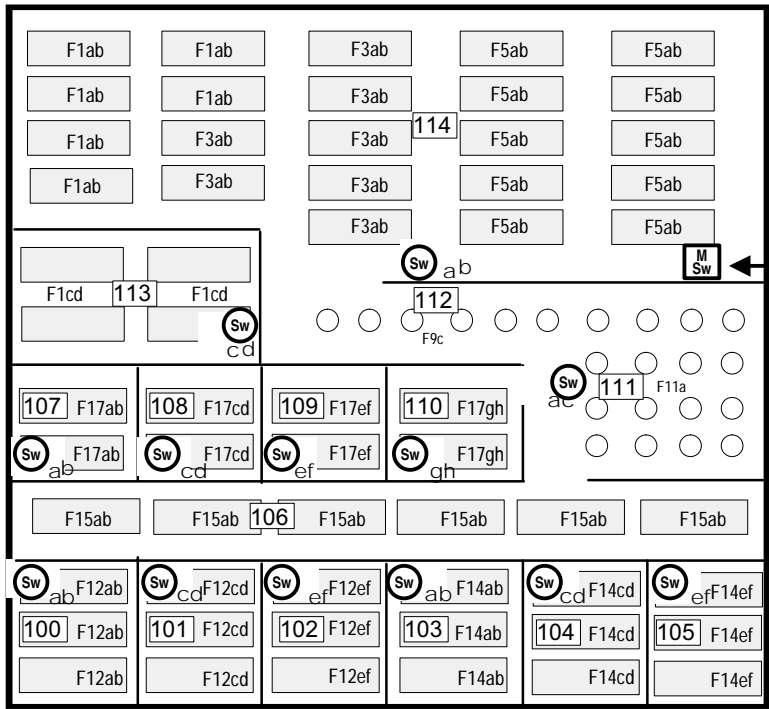
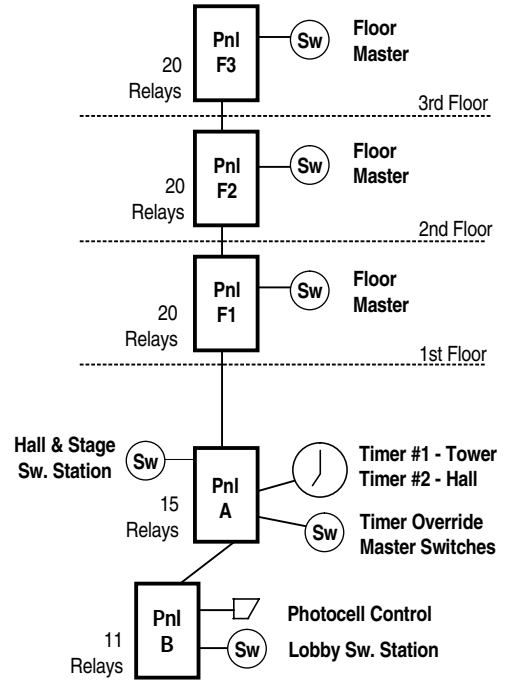

The **Reflected Ceiling Plan** assists in determining the location of local switches and master switches and the wiring distance to the relay panels.

The **Relay Schedule** - identifies the materials the manufacturer needs to provide in order to bid the project. (See the example on the following page.)

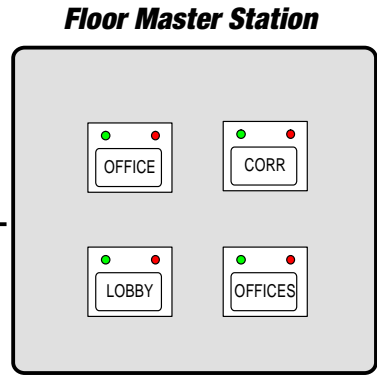

RELAY SCHEDULE

PROJECT: The office

PANEL #: F

Circuit #	Relay #	Description	Local Switch	Master Switch	T/C Group	P/C Group	Comments
F1a	1	Open Office 114 - 50%	114a	1	1		
F1b	2	Open Office 114 - 50%	114b	1	1		
F3a	3	Open Office 114 - 50%	114a	1	1		
F3b	4	Open Office 114 - 50%	114b	1	1		
F5a	5	Open Office 114 - 50%	114b	1	1		
F5b	6	Open Office 114 - 50%	114a	1	1		
F1c	7	Boardroom 113 - 50%	113c	2	1		
F1d	8	Boardroom 113 - 50%	113d	2	1		
F9c	9	Corridor 112	111b	3	2		
F11a	10	Lobby 111	111a	1	3		
F15a	11	Corridor 106 - 50%		3	2		
F15b	12	Corridor 106 - 50%		3	2		
F12a	13	Office 100 - 50%	100a	4	4		
F12b	14	Office 100 - 50%	100b	4	4		
F12c	15	Office 101 - 50%	101c	4	4		
F12d	16	Office 101 - 50%	101d	4	4		
F12e	17	Office 102 - 50%	102e	4	4		
F12f	18	Office 102 - 50%	102f	4	4		
F14a	19	Office 103 - 50%	103a	4	4		
F14b	20	Office 103 - 50%	103b	4	4		
F14c	21	Office 104 - 50%	104c	4	4		
F14d	22	Office 104 - 50%	104d	4	4		
F14e	23	Office 105 - 50%	105a	4	4		
F14f	24	Office 105 - 50%	105b	4	4		
F17a	25	Office 107 - 50%	107a	4	4		
F17b	26	Office 107 - 50%	107b	4	4		
F17c	27	Office 108 - 50%	108c	4	4		
F17d	28	Office 108 - 50%	108d	4	4		
F17e	29	Office 109 - 50%	109e	4	4		
F17f	30	Office 109 - 50%	109f	4	4		
F17g	31	Office 110 - 50%	110g	4	4		
F17h	32	Office 110 - 50%	110h	4	4		

LOW VOLTAGE DESIGN CHECKLIST

The **one line diagram** assists the contractor in determining wire runs and connection details when multiple relay panels are involved.

The **reflected ceiling plan** assists in determining the location of local switches, and master switches and the wire runs to the relay panels.

The **relay schedule** identifies the materials the manufacturer needs to provide in order to bid the project. (See following pages for step by step instructions)

- Lay out the electrical circuits according to established design procedures. Douglas relays are rated for use with all lighting loads and can control a fully loaded 20A 277V or 347V circuit. After laying out the lighting circuits on the reflected ceiling plan, identify which circuits are to be relay controlled. Some circuits may have more than 1 relay.
- Enter the circuit numbers and relay identification on the relay schedule.
- Determine which relays are to be controlled by local switches, indicate location on the reflected ceiling plan and indicate quantity on the relay schedule.
- Determine which groups of relays are to be controlled by master switches and show their location on the reflected ceiling plan. Enter this information in the appropriate column on the relay schedule.
- Indicate the different time clock zones on the relay panel schedule. Actual ON/OFF time schedules can be done now or later.
- Decide which relays (if any) you want controlled by photocell and indicate these on the relay panel schedule.
- Note any special requirements such as Building Automation System Interface, Emergency Circuits to be controlled, etc in a brief paragraph associated with the relay panel schedule.

RELAY SCHEDULE

PROJECT: ABC Company

PANEL #: LC-1

Circuit #	Relay #	Description	Local Switch	Master Switch	T/C Group	P/C Group	Comments
1	1	Corridor #1 50%		A	2		
3	2	Corridor #1 50%		B	3		
5	3	Lunch Room		F	1		
7	4	Entrance	2	C	4		
7	5	Office 1		F	1		
7	6	Office 2	1	F	1		
9	7	Office 3	1	F	1		
9	8	Admin Area 50%	1	F	1		
13	9	Admin Area 50%	2	F	1		
17	10	Wash Room - Women	2	F	1		
17	11	Meeting Rooms 50%	1	F	1		
19	12	Meeting Rooms 50%	1	F	1		
21	13	Wash Room - Men	1	F	1		
21	14	Corridor #2 50%		A	2		
2	15	Corridor #2 50%		B	3		
4	16	Exterior		D		1	
6	17	Exterior		D		1	
8	18	Parking		E	4	2	
10	19	Parking		E	4	2	
12	20	SPARE					
14	21	SPARE					
16	22	SPARE					

Step 6: Identify which relays are switched by time clock. If different groups are switched at different times, then each zone should be noted opposite each relay.

Step 7: Indicate which relays are controlled by photocell, if they are not all to go off together, then identify as two zones. Indicate miscellaneous notes if applicable

Step 8: BLANK PANEL SCHEDULE IS AVAILABLE ON THE SPECIFICATION DISK LOCATED IN THE CATALOG COVER POCKET. IF THE DISK IS MISSING, CONTACT YOUR LOCAL REPRESENTATIVE, OR DOUGLAS.

