

	PART No.	DESCRIPTION	SPECIFICATION
		<ul style="list-style-type: none"> Douglas relays are 2-wire latching relays that are lighting load rated for standard 20A branch circuits. Douglas 2-wire heavy duty HID relays are suitable for all types lighting loads including capacitor corrected HID ballasts. Manual operation lever and indicator are built-in for convenient operation and status check at the panel. Douglas HID relays are available with auxiliary contacts on the low voltage side of the relay. Contact not required for Douglas system, but may have application for specialty requirements. Douglas HID 2-pole relay is available with a 480V rating intended for 480V lighting applications. 	<p>Control Input</p> <ul style="list-style-type: none"> Class 2 circuit. 0.350A (350mA). 24 volt reversible polarity pulse. Input terminals: #16 - #20 AWG. <p>Output Contact Ratings</p> <ul style="list-style-type: none"> More than 30,000 operations with 20A load, 2000A inrush @ 20 times / min. switch speed. UL Listing <ul style="list-style-type: none"> 20A 300 VAC 2400 W 120 VAC "T" 20A 300 VAC "F" 20A 480 VAC "F" (WR-6172 only) UL Endurance Test 150,000 cycles SCCR Rating: <ul style="list-style-type: none"> 14KA (WR-6161, WR-6161-3) 5KA (WR-6172, WR-6172-3). CSA Certifications <ul style="list-style-type: none"> 20A 347 VAC 2400 W 120 VAC "T" 20 A 347 VAC "F". Output terminals: #10 to #14 AWG. <p>Environment</p> <ul style="list-style-type: none"> Indoors, stationary, non-vibrating, non-corrosive atmosphere and non-condensing humidity. Ambient temperature: -20°F to +120°F (-28°C to +50°C).
	WR-6161	1 pole HID relay 20A : 120/277/347	
	WR-6161-382	1 pole HID relay with aux contacts 20A : 120/277/347 (aux contacts 1A : 125VAC)	
	WR-6172	2 pole HID relay 20A : 120/277/347/480	
	WR-6172-382	2 pole HID relay with aux contacts 20A : 120/277/347/480 (aux contacts 1A : 125VAC)	

WR-6161 HID Relay

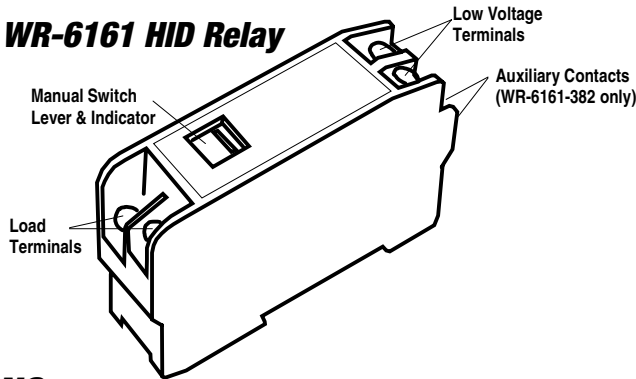

CONNECTIONS

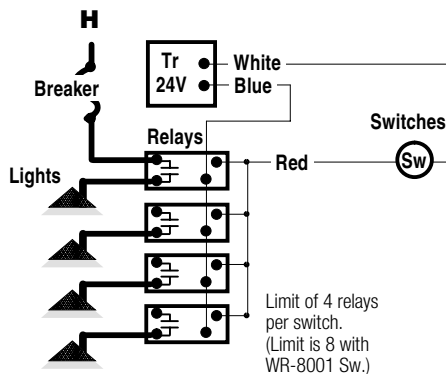
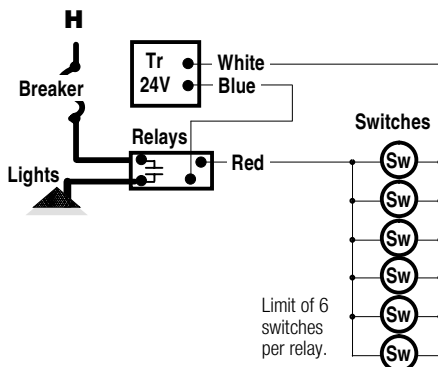

Note:

- The 2 pole relay (WR-6172) has the same input ratings as the 1 pole relay. Use this feature to double the load switching capacity of a low voltage switch.

DIMENSIONS & MOUNTING

- WR-6100 series relays mount to a snap rail built into Douglas PWEx series relay panels.

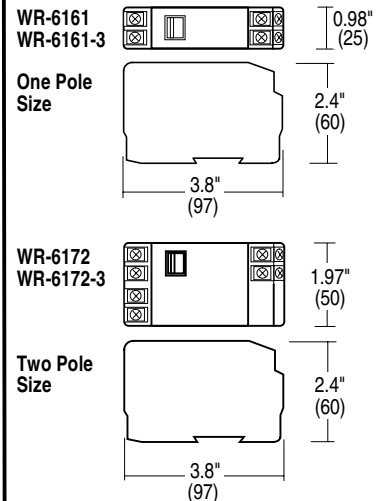

2-WIRE RELAY TECHNOLOGY

- Douglas 2-wire relays utilize an ingenious control method that permits simple and minimal wiring. All functions for low voltage control: **on**, **off**, **indication** and **location** are provided with only a 2-wire connection of which one is often a common. All Douglas relays manufactured over the past 30 years utilize the same principle. Thus, any Douglas switching device is compatible with any model of Douglas relay.

Operational Principle

- A negative pulse turns the relay ON and a positive pulse turns it OFF. Using a diode, an AC signal can be rectified to turn the relay either ON or OFF. Douglas switches have 2 diodes built into the switch to provide the ON and OFF signals.
- The relay has 2 similar diodes built inside that are in series with the relay coil. The diodes in the relay act as gates for the switch signal.
- To turn the relay ON or OFF, the rocker switch completes the circuit by selecting the ON or OFF diode. If the diode selected is in the same direction as the gate diode in the relay, the relay will switch. If the gate diode is not in the correct direction, then nothing will happen since the relay is already in the correct state for the action selected by the switch. When the switch is released, a spring returns it to the central neutral position.
- Indication (ON state) and location (OFF state) are obtained by utilizing LED diodes built into the switch. Only the LED which is connected in the same direction as the gate diode in the relay will light. Although the LED current passes through the relay coil, it is not large enough to cause the relay to trip. However, there is a limit: the maximum number of LED switches that can be connected to the same relay is 6.
- For additional convenience (especially during installation) all standard models have a manual control lever and indicator permitting a non-electrical method of switching and status check at the panel.

Detailed 2-wire Relay / Switch Circuit

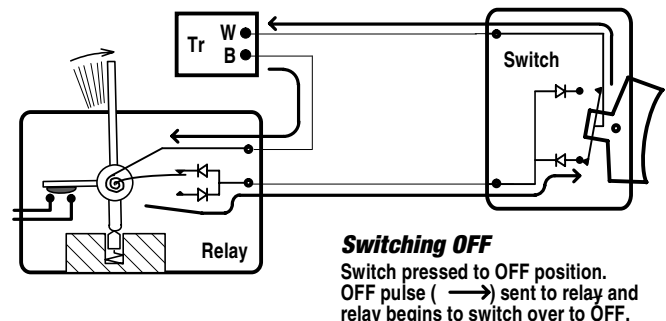
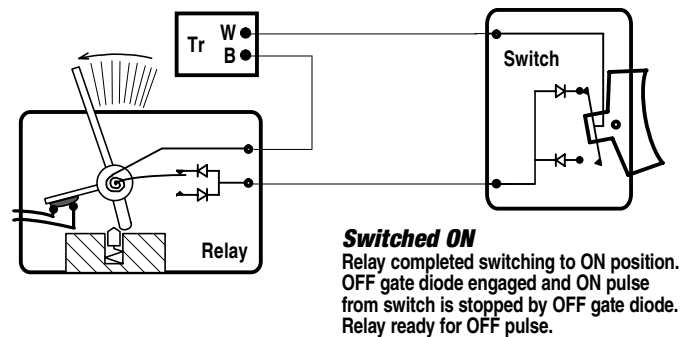
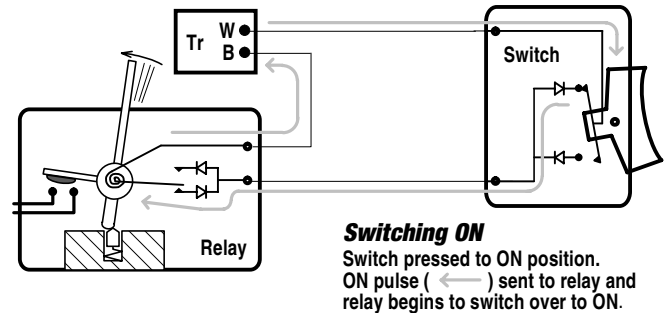
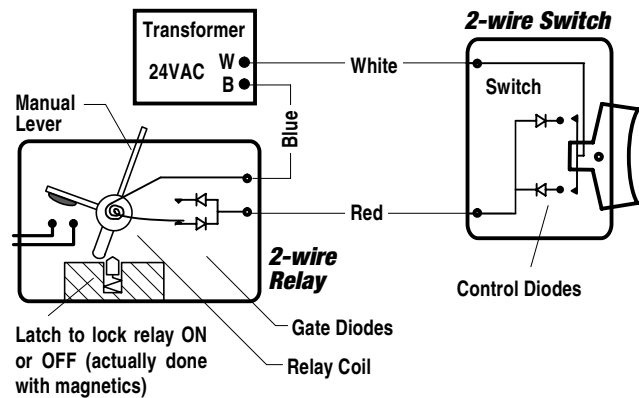

Detailed LED Switch Circuit *

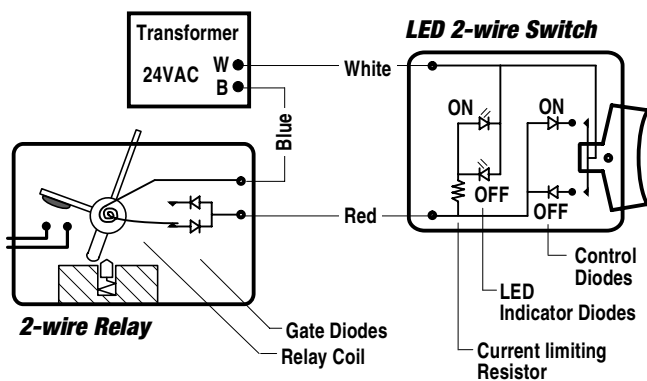

* LED Switch circuit actually not as shown. Switch is functionally similar except rocker switch is replaced with single push button.

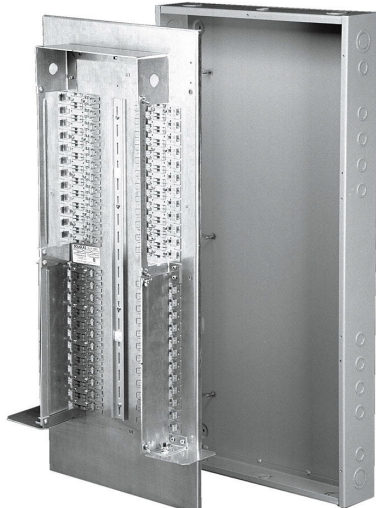
	PART No.	DESCRIPTION	SPECIFICATION
	PWEx Panels	<ul style="list-style-type: none"> Douglas PWEx series relay panels are a versatile line of panels used for WR- 6161 and WR-6172 relays. Standard sizes range from 6 to 72 relays. (Note: WR-6172 = 2 relays). A panel consists of the enclosure (tub), the interior and the cover. Enclosures are installed in the rough-in stage and interiors are installed and connected after wires are pulled. Interior has snap brackets for mounting relays and DIN rail in the centre for mounting control components. Box knockouts are located so that panels of the same horizontal or vertical dimension can be joined with conduit nipples. 	<ul style="list-style-type: none"> Enclosures and covers are made of steel coated with ANSI/ASA 61 Grey. Coating is heat fused polyester epoxy finish applied on all surfaces. Interior insert is made from aluminium, steel and plastic parts. <p>Certifications</p> <ul style="list-style-type: none"> UL listed, CSA approved EEMAC/NEMA 1 Standard <p>Options</p> <ul style="list-style-type: none"> Hinged, surface or flush covers. Covers are reversible for either left-to-right or right-to-left door opening. Dripshoods (surface mount only). NEMA 3 standards. Special paint colors. Voltage dividers to divide line voltage compartment for different line voltages.

PWEx Panel Numbering System

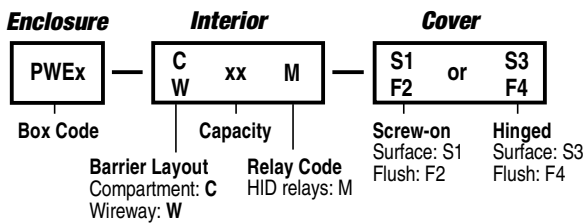

Compartment Style Barrier Layout

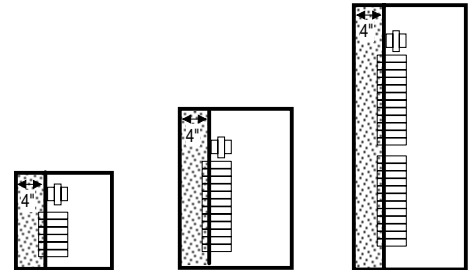

CAPACITY	6	12	24
PART No.	PWE0 - C06M - **	PWE1 - C12M - **	PWE2 - C24M - **
SIZE (H x W x D)	12 x 12 x 4.25	20 x 14 x 4.25	33 x 14 x 4.25

** Add cover style number at end of P/N

Wireway Style Barrier Layout

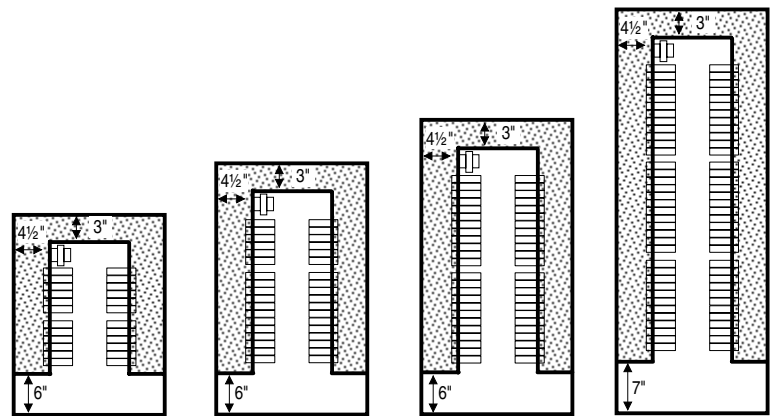

Symbols

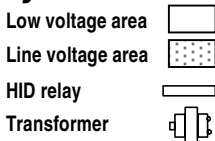

CAPACITY	24	36	48	72
PART No.	PWE3 - W24M - **	PWE4 - W36M - **	PWE6 - W48M - **	PWE8 - W72M - **
SIZE (H x W x D)	27 x 20 x 4.25	33 x 20 x 4.25	39 x 20 x 4.25	54 x 20 x 4.25

** Add cover style number at end of P/N

PWEx Panels: Exploded View

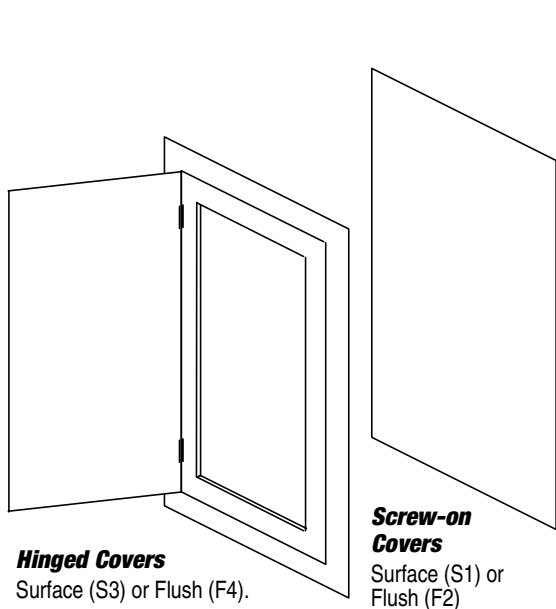

Hinged Covers

Surface (S3) or Flush (F4).
 Install right side up or upside down for right-to-left or left-to-right door.
 The inner trim of the hinged cover covers over all of the line voltage wiring. Access to the relay's manual control levers is in the low voltage compartment.

Screw-on Covers

Surface (S1) or Flush (F2)

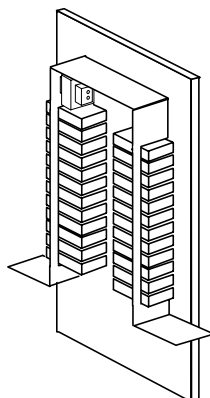

Relay Interior

Relays mount to HID snap rails. Barriers are located to provide the line / low voltage division. Transformers mount to 1/2" knock outs located in the barrier. Control components are mounted to DIN rail in center of interior. Pre-assembled PWEx panels will have panel schedules completed according to information provided and all low voltage control connections pre-wired.

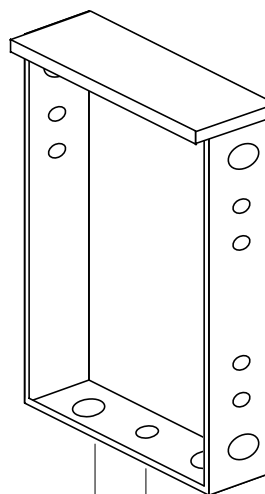

Drip Shields

Optional, surface cover panels only.

Stacking Panels

Panels of equal dimension on a side have matching KO pattern to provide easy stacking.

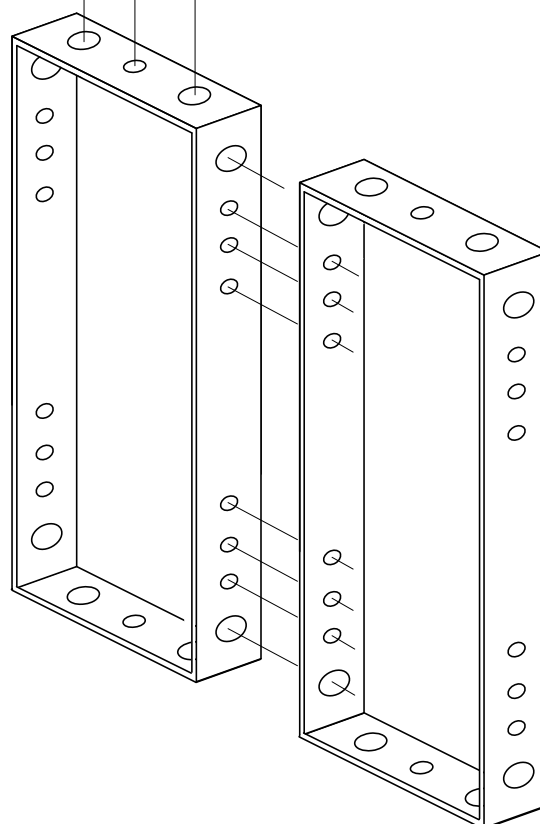

INSTALLATION & ASSEMBLY

- PWEx series relay panels for Douglas HID relays are supplied with a separate interior. All of the components and barriers are mounted to the interior.
- PWEx panels are primarily intended for projects where the interior is factory pre-assembled. To install the relay panel the following sequence is recommended:
 - 1) Mount the empty enclosure onto the wall and pull wires. It is recommended that all (or most) of the wires be pulled prior to installing the interior. This will prevent component damage from the wire pulling operation.
 - 2) Relay line voltage terminals are sized for a maximum of 12AWG wire.
 For low voltage wiring 18AWG solid is recommended.
 - 3) Once the wires have been pulled, install the interior and bolt it into place. Make line connections to relays according to the panel schedule provided. If there is no schedule, identify circuits on a blank schedule.
 - 4) To test circuit, turn circuit breaker off, use manual lever to turn relay on and then turn on the circuit breaker. This will help prevent relay contact welding due to dead shorts.
 - 5) Verify that the schedule matches the lights operated by the relay.
 - 6) Once the line circuits are connected and verified, connect low voltage switch wiring to relays or devices.