

| PART No. | DESCRIPTION | SPECIFICATION |
|--------------------------|--|--|
| WNX-2624 Network Node | <ul style="list-style-type: none"> The WNX-2624 Network Node permits Douglas WRS-2224 Relay Scanners to be networked together. The WNX-2624 Node uses state-of-the-art LonWorks® networking technology and is LonMark® certified (3.1). WNX-2624 nodes can be networked in one of 2 methods. <ol style="list-style-type: none"> Self-configured network (default) Externally configured network <p>Self-Configured Networks</p> <ul style="list-style-type: none"> Self-configured networks are ideal for expanding the number of relay outputs controlled by a scanner switch input. When networked, the switch input of a scanner has global reach and can control any quantity of relay outputs throughout the system. <p>Externally Configured Networks</p> <ul style="list-style-type: none"> Other control systems that use LonWorks technology can digitally integrate the WNX-2624 as a part of that system. This requires that the other system has the necessary features, software and interface for lighting control. The WNX-2624 node is LonMark certified, and will accept all the LonWorks commands relevant for lighting control. | <p>Power</p> <ul style="list-style-type: none"> The WNX-2624 network node obtains power from the host WRS-2224 relay scanner. CAUTION: Always disconnect 24VAC from the scanner prior to plugging/unplugging the WNX-2624 unit. <p>Wire Type & Method</p> <ul style="list-style-type: none"> Nodes are connected together with a 2-wire cable. Use 16 AWG, twisted pair, unshielded cable. Stranded or solid conductor. Refer to "INSTALLATION - LonWorks Data Signal Wiring" for more details. Free topology network wiring is supported. Data signal can be wired with branches and tees. Overall network wire length should not exceed 1650 feet (500m). Longer data signal lengths are possible if devices are connected in a serial bus. Optionally a repeater can be used to increase data signal length. Connections are not polarity sensitive. <p>Network Operation & Size</p> <ul style="list-style-type: none"> Simple basic networks are self-configured and up to 24 nodes can exist in a system (WNX-2624 and WNS-2308 nodes). The WNX-2624 and WNS-2308 nodes can also be integrated into other systems that use the LonWorks technology. <p>Networking Technology Specification</p> <ul style="list-style-type: none"> LonWorks® technology LonMark® Certified (V3.1). Network signal: FTT-10 Transceiver. <p>Environment</p> <ul style="list-style-type: none"> Environment: Indoors, stationary, non-vibrating, non-corrosive atmosphere and non-condensing humidity. Ambient temp: +15° to +120°F (-10° to +50°C) <p>DIMENSIONS & MOUNTING</p> <ul style="list-style-type: none"> Be sure to disconnect 24VAC from relay scanner before plugging/unplugging network node into scanner. Mount node to 35mm DIN rail installed in Douglas relay panel. |

Relay Outputs

24 output terminals (12 per side), are provided for relay control. Douglas 2-wire switches can be connected in parallel to permit individual control of a relay by switch.

Select Buttons & LED's for:

- 1) Operating mode
- 2) Program mode
- 3) Flick Warn before OFF Option

Directions

Directions are printed on keypad for handy user reference. Controls on WNX-2624 are used for reviewing node address and switch codes.

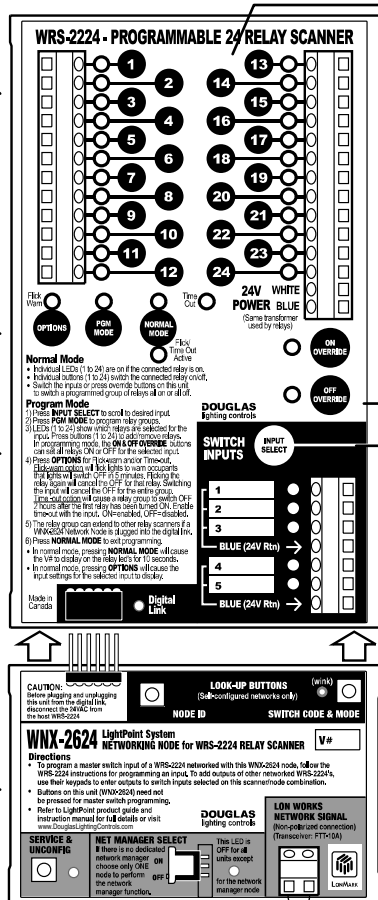

Individual Output Buttons

In operating mode, use buttons to switch the connected relay ON or OFF. In programming mode, use buttons to enter or remove the relay from the input being programmed.

Override Buttons

Use ON and OFF override buttons to switch relay groups.

Relay Group Select

Use the relay group select button to choose the relay group input 1,2,3,4 or 5. The selected input will have its led ON.

Data Signal

FTT-10 transceivers are used to communicate the LonWorks protocol. Data signal cable is #16AWG, twisted pair,

Networking Technology Specification

- LonWorks® technology LonMark® Certified (V3.1).
- Network signal: FTT-10 Transceiver.



Environment

- Environment: Indoors, stationary, non-vibrating, non-corrosive atmosphere and non-condensing humidity.
- Ambient temp: +15° to +120°F (-10° to +50°C)

DIMENSIONS & MOUNTING

- Be sure to disconnect 24VAC from relay scanner before plugging/unplugging network node into scanner.
- Mount node to 35mm DIN rail installed in Douglas relay panel.

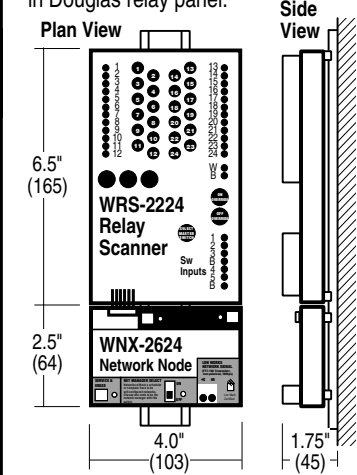

| PART No. | DESCRIPTION | SPECIFICATION |
|---|--|--|
| <p>WNS-2308 Eight Input Node</p> | <ul style="list-style-type: none"> The WNS-2308 Input Node provides EIGHT inputs that can control any group of relays in a Douglas system using networked WRS-2224 scanners. The inputs of the WNS-2308 can each be configured to be compatible with a variety of hardware types and can be configured to operate in a specific manner. The default configuration is: Douglas 2wire relay switch operating in the ON/OFF mode. Please refer to the table below for the complete list of hardware types and switch modes available. The WNS-2308 uses state-of-the-art LonWorks® networking technology and LonMark certified control objects for lighting control. The WNS-2308 Input Node can be used in one of 2 methods: <ol style="list-style-type: none"> Self configured Network (default) Externally configured Network <p>Self-Configured Networks</p> <ul style="list-style-type: none"> Use in a self configured network to add inputs. <p>Externally configured networks</p> <ul style="list-style-type: none"> Other controls systems that use LonWorks technology can digitally integrate the WNS-2308 as a part of the other system. | <p>Power</p> <ul style="list-style-type: none"> 24VAC, 100mA <p>Wire Type & Method</p> <ul style="list-style-type: none"> Nodes are connected together with a 2-wire cable. Use 16 AWG, twisted pair, unshielded cable. Stranded or solid conductor. Refer to "INSTALLATION - LonWorks Data Signal Wiring" for more details. Free topology network wiring is supported. The data signal can be wired with tees and branches. Overall network wire length should not exceed 1650 feet (500m). Longer data signal lengths are possible if devices are connected in a serial bus. Optionally, a repeater can be used to increase data signal length. Connections are not polarity sensitive. <p>Network Operation & Size</p> <ul style="list-style-type: none"> Simple basic networks are self-configured and up to 24 nodes can exist in a system. (WNS-2624 and WNS-2308 nodes). The WNS-2624 and WNS-2308 nodes can also be integrated into larger systems that use the LonWorks technology. <p>Networking Technology Specification</p> <ul style="list-style-type: none"> LonWorks® technology LonMark® Compliant Network signal: FTT-10 Transceiver. <p>Environment</p> <ul style="list-style-type: none"> Environment: Indoors, stationary, non-vibrating, non-corrosive atmosphere and non-condensing humidity. Ambient temp: +15° to +120°F (-15° to +50°C) |

Hardware & Switching Mode Options

The table below is printed on the membrane key pad for easy reference. (The WNS-2308 is shown with the peel-away description label applied)

Below is a reprint of the table to show the different hardware types and switching modes available from the keypad of the WNS-2308.

In many cases, other systems are integrated with a contact closure. Use the table to determine the appropriate hardware type for the control supplied.

| Sw Mode | Hardware Type |
|-------------------|--|
| OFF only | AC Mom ON |
| ON Only | AC Mom OFF |
| Flick | AC NC=ON, NO=OFF |
| TimeOut | AC NC=OFF, NO=ON |
| TimeOut & Flick | AC NC=ON, NO=None |
| Delay OFF | AC NC=OFF, NO=None |
| Delay OFF & Flick | AC NC=None, NO=ON |
| Delay ON | AC NC=None, NO=OFF |
| Housekeeping ON | Douglas 2wire Switch DC Pos=OFF, Neg=ON |
| Wink (Sentry) | DC Pos=ON, Neg=OFF |
| Regular ON/OFF | DC No Status Signal |
| Redo ON/OFF | Disabled |
| Sw Mode | Hardware Type |

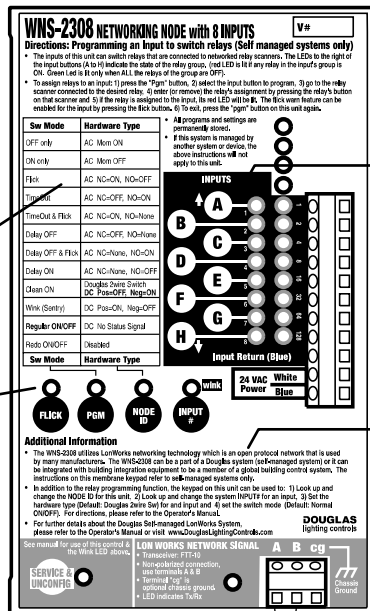

Master Switch Override Buttons

Use input buttons A to H to switch inputs ON/OFF.

Led's show status of relay group assigned to the input.

Directions

Basic programming directions are printed on keypad for handy user reference.

Detailed directions for specialized settings are in user manual.

Select Buttons & LEDs for:

- Program mode
- Hardware options
- Input switching mode settings including the flick warn option.
- Input # and unit ID settings

Data Signal

FTT-10 transceivers are used to communicate the LonWorks protocol. Wiring is simple 16AWG twisted pair, unshielded wire, stranded or solid.

DIMENSIONS & MOUNTING

- The WNS-2308 mounts to 35mm DIN rail in Douglas relay panel.

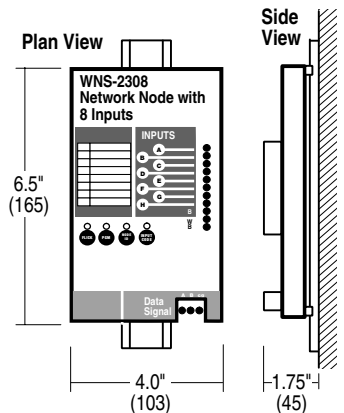

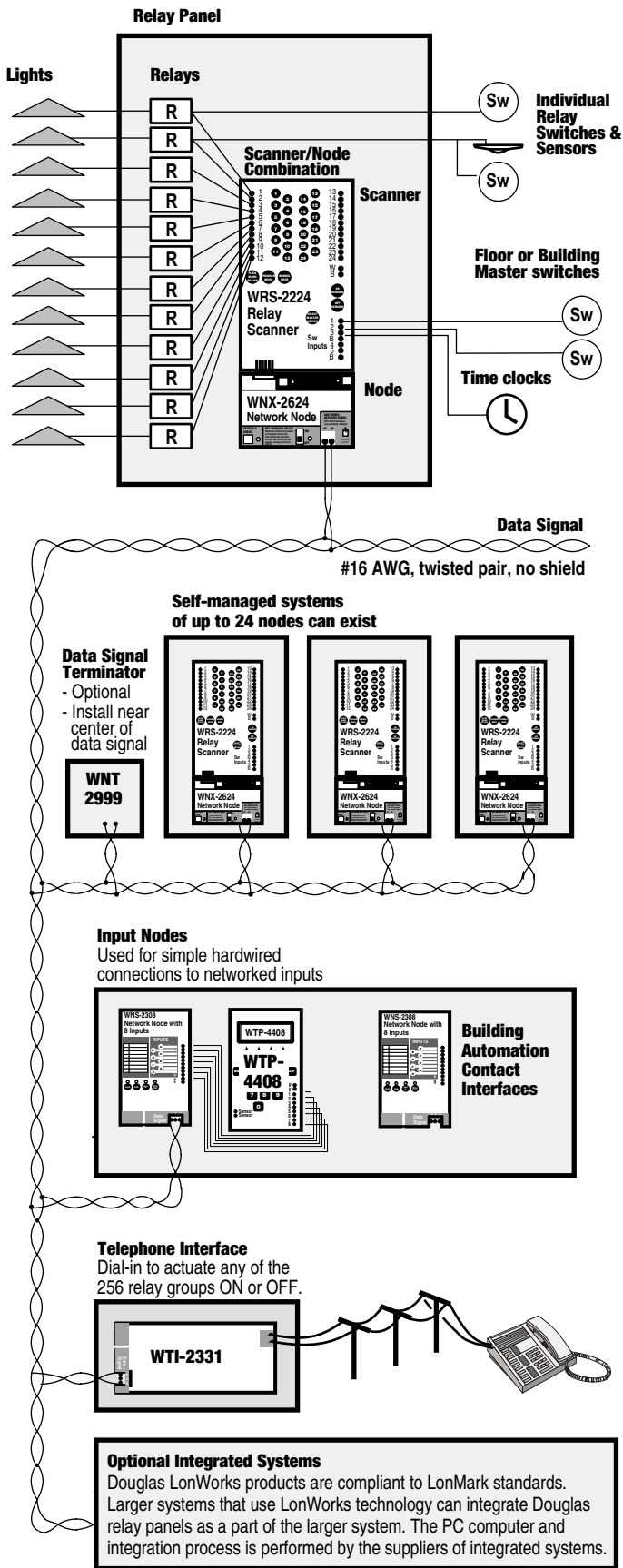

CONNECTIONS

- Douglas relays and switches can be easily networked by using relay scanners equipped with network nodes. Local switches and sensors are still connected directly to relays and system wide switches/timers are connected to the inputs of the scanner/node combination.
- For system wide control of relays, connect a standard Douglas 2-wire switch and/or timer output to a scanner input. By using the membrane buttons built into the scanners, the relays controlled by an input are easily selected or de-selected.
- Each input of a scanner is unique. That is, input 1 of scanner 1 can be set to control relays connected to scanners 1,2,3 etc. Input 1 of scanner 2 can be set to control a different group of relays that are connected to scanners 1,2,3 etc.
- By attaching a WNX-2624 network node to a WRS-2224 relay scanner, a simple, self-managed network can be established. The WNX-2624 nodes are connected together with a non-polarized data signal that can be connected to the devices in either way.
- Total data signal length should not exceed 1650 feet (500m). If longer lengths are required (to a maximum of 7000 ft./2700m), wire the data signal from node-to-node in sequence (no tees or branches) or use a repeater.
- The WNX-2624 Scanner Node is LonMark certified to ensure reliable, predictable operation with other control systems that integrate Douglas relay panels as a part of their system.

APPLICATION

Simple, Self-configured Networks

- A self configured network only requires the network nodes to be plugged into the relay scanners and connected together via data signal. For one of the network nodes, set the network manager switch to "ON" and ensure that the rest of the switches are OFF. The node with the switch set to ON performs the network manager functions of configuration and address assignment.
- Use the membrane key pads built into the scanners to set which relays are controlled by an input. Any relay output that is part of the network can be programmed to an input.
- Each relay scanner has 5 inputs and 24 relay outputs. If additional inputs are required at a location, use the WNS-2308 EIGHT Input Networking Node.
- A self-configured system can support up to 24 nodes. This provides over 500 relay outputs and 120 inputs.
- The flick warn and time out options supported by a stand-alone WRS-2224 Relay Scanner are also supported on the self-configured network. If the input has an option selected with the keypad of the WRS-2224, the system wide relay group will have the same feature. The WNS-2308 also supports the flick warn feature.
- The WNS-2308 unit has additional features that allow the inputs to accept control from devices that do not use the Douglas 2wire switching method. Contact closures of maintained or momentary nature are easily interfaced to the WNS-2308.

Externally Configured Networks

- Douglas LonWorks based products can be configured and controlled by an external host system that uses the LonWorks standards. For programming and operating details of such systems, please refer to the documentation of the host system.

APPLICATION (continued)

Integrated Systems

- The LonWorks technology used by the Douglas Scanner/Node combination is a non-proprietary, open-architecture standard for building control networks. Other LonWorks based systems can incorporate a Douglas lighting control panel as a part of the other system provided the other system supports lighting controls.

LonWorks® TECHNOLOGY

- To integrate different manufacturers devices and systems at a network level demands that common standards are in place today and in the future. The LonWorks technology provides a stable, common and open networking standard.
- Douglas Lighting Controls is a LonMark partner and we have developed our LonWorks products to comply to the LonMark certification standards for open systems. This ensures our customers reliable and predictable performance when integrating Douglas product with other systems.



Basics for Systems Integrators

- For building control designs that wish to take advantage of integrated systems, Douglas products can be integrated as a part of a greater system that uses the LonWorks network platform.
- LNS plugins are available for control and configuration of the objects listed in the table below. The LNS plug-ins are written in Visual Basic and are designed to plug-in to the LNS software engine used by many LonWorks Integrators.
- For more information visit: www.DouglasLightingControls.com

| LonMarked Variables used by Douglas Products | |
|--|--|
| Functional Profile (Object) | Network Variable & Type |
| <i>Lighting Panel Controller (LPC)</i> (This object receives group commands, activates relay groups and returns status on relay groups. The trigger would be from a Scene Panel Object.) | <i>nviGroup/nvoGroupFb</i> <i>SNVT_Scene</i> |
| <i>Scene Panel</i> (This object issues group commands and receives the relay group status. The typical destination would be an LPC Object) | <i>nvoScene/nviScenFb</i> <i>SNVT_Scene</i> |
| <i>Actuator (24 objects per node)</i> (This object receives commands from a switch to activate a relay and returns status. The typical trigger would be from a Switch Object.) | <i>nviLampValue/nvoLampValueFb</i> <i>SNVT_Switch</i> |
| <i>Switch (5 objects per node)</i> (This object issues commands to activate a relay or other On/Off devices. The typical destination would be an Actuator Object). | <i>nvoSwitch</i> <i>SNVT_Switch</i> |

Note: Self-managed systems only use the *Lighting Panel Controller* Object and the *Scene Panel* Object. The *Actuator* and *Switch* Object are provided to permit outside systems to operate individual relays.

INSTALLATION

System ID's and Configuration

- The nodes used in either self-configured or integrated systems each have a unique ID. Self-configured systems use the facilities of one of the nodes to assign ID#s. This node is called the network manager and has the network manager switch set to "ON". Once assigned, ID#s are permanently stored in the node and can only be changed with a special procedure.
- When a WNX-2624 or WNS-2308 Node is first used it does not have a system ID. When it is connected to a self-configured system the system will recognize that the node is present and has no ID. The network manager node will then assign to the node an available ID (a number from 1 to 24).
- If all of the nodes of a self-configured system need network IDs, the ID numbering process may take a few minutes. Once assigned, the ID numbers are retained indefinitely. Adding new nodes in the future causes the auto ID process to occur for the added nodes.
- Integrated systems assign ID numbers with the system manager used by the integrated system. When a node is configured by an outside, integrated system, the network manager switch of the node is automatically disabled to prevent any network management conflicts with the integrated system manager.

LonWorks Data Signal Wiring

- The Douglas network nodes use FTT-10 transceivers to carry the LonWorks Data Signal. The FTT-10 transceiver is well suited for a building environment. It is robust, has a great deal of noise immunity and supports free topology installation.
- The FTT-10 transceivers (FTT = Free Topology Transceiver) support "free topology" wiring. Free topology allows the installer to branch and "T" the data signal as required. In addition, the data signal has no polarity and connections can be made to devices in either direction. As a comparison, RS-485 transceiver systems can only be wired as a bus (nodes wired in succession with no branches in wire) and the wire pair is polarity sensitive.
- Data Signal total wire lengths:
 - Free topology connections: 1650 feet (500meters) maximum.
 - Serial bus connections: 7000 feet (2700 meters) maximum. (FTT-10 wired as a bus has improved range)
- Data Signal Polarity: None
Douglas nodes can be connected to the wire pair in either way.
- Wire Type: #16 AWG, twisted pair, no shield, solid or stranded. (Example: Belden #8471)
- Other wire types can be used, however results will vary depending upon the wire type and gauge. Please contact factory for information about different wire types.
- Do not install the data signal in close proximity (less than 3") to higher voltage cables and conduit.
- If longer data signal wiring lengths are needed, use a repeater (contact factory).

WLP-2999 Termination Unit

- The WLP-2999 Terminator unit helps provide additional noise immunity for the Data Signal wiring. The device is recommended, but is optional and lack of use will not affect warranty. Best results are obtained if the terminator can be installed at approximately the physical center of the network wiring.