

W-2000

Lighting Control Systems & Products

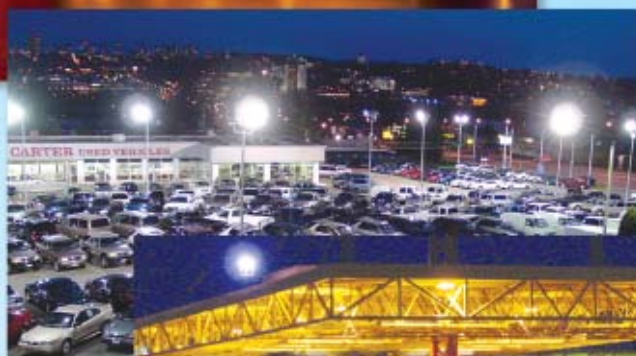

- Flexible Upgrade Path
- PC Interface with no Proprietary Software
- Internet Browser Technology
- Access Direct or via the Internet

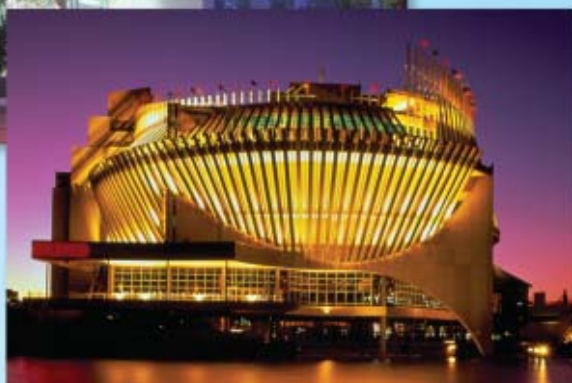

DOUGLAS
lighting controls

W-2000

Lighting Control Products & System Configurations

W-2000 Controls and Douglas Relay Panels

The fundamental platform of the W-2000 Lighting Control System is a Douglas Relay Panel with a Scanner/Node combination.

Lighting branch circuits connect to Douglas 2-wire relays. The relays are controlled by Programmable Relay Scanners (WRS-2224) equipped with a Network Node (WNX-2624).

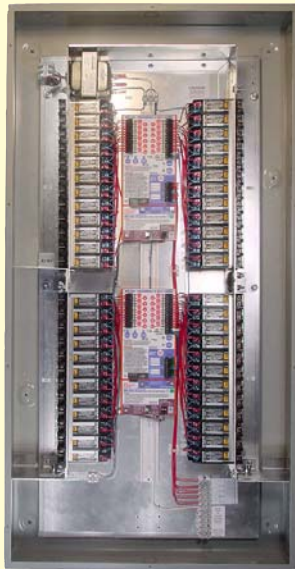

W-2000 Panel Network

The Scanner/Node combinations within the panels are connected to each other with a 2-conductor data line. This forms the backbone of the W-2000 system by providing an address point for each relay.

The W-2000 family of products uses the *LonWorks* technology platform to provide an open standard, non-proprietary option for your system. Other building automation systems that support lighting controls using the *LonMark* Standards can integrate the Douglas panel network as a part of their system.



data signal

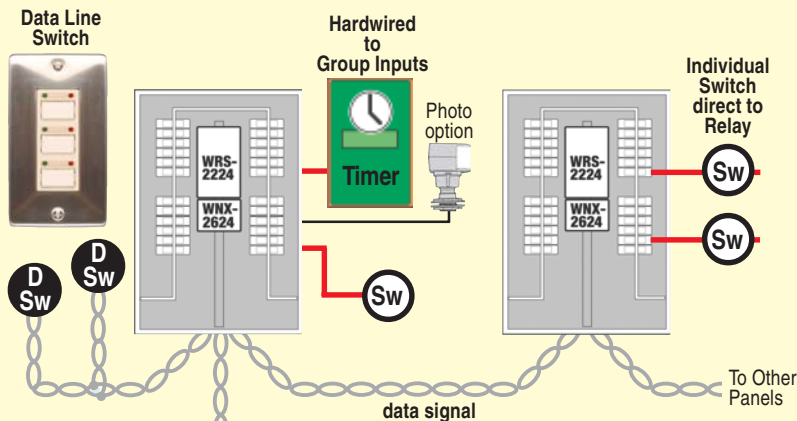

Switching & Inputs

Relays can be individually switched by connecting a Douglas 2-wire Switch directly to the relay, or they can be switched as a group by connecting to an input in the system.

To actuate a group, connect a Douglas 2-wire Switch or Time Clock to a group input on the relay scanner. Also, Douglas Data Line Switches can be connected directly to the data line and can be programmed to actuate any relay or group within the system.



data signal

To Network Manager (optional)

W-2000 System Configurations

Self-Configured

In the self-configured mode (as shown on page 2), all group switching and programming of groups can be accomplished without any further equipment such as a PC or external programming device.

User LEDs and buttons built into the Scanner/Node combinations are all that are required to set and program the relay groups. You can connect switches to inputs to actuate relay groups. You can also connect Data Line Switches direct to the data line to actuate relay groups anywhere in the network.

Configured by an External System

The W-2000 Lighting Control System uses *LonWorks*® technology, an open system protocol.

The Douglas Scanner/Node combination can be controlled by any Building Automation System (BAS) that uses *LonMark* standards for lighting controls. Douglas W-2000 components are *LonMark* certified to ensure easy compatibility when integrated into another system.



LONMARK
PARTNER

Configured by a WNP-2150 Network Manager

The WNP-2150 *Network Manager* provides a number of additional features to a W-2000 system:

- Uses any standard Internet browser for system access.
- Accesses directly via an ethernet connection or remotely via the Internet.
- Does not require the PC for normal operation.
- Allows view/edit of all relay groups in the system.
- Allows switching options such as Flick Warn, Time Out, Delay OFF, Cleaning Mode and Disable features.
- Automates schedules including weekday and holiday events.
- Supports photo, astronomic and time functions.
- Displays logs of last 255 events.
- Allows for the creation of relay panel schedules with names for each relay group and input.
- Allows uploading or downloading of programming or configuration data via the Internet or telephone line.

Configured by a WNP-2150 Network Manager



Ethernet
Connection

No software required:
use Internet Browser



data signal

To Panel Network



Internet Access

WNP-2150 Network Manager settings are viewed and edited with a standard Internet browser. No proprietary software required.

User connection to the WNP-2150 can be direct with an ethernet connection or remote from a computer that is connected to the Internet. Telephone access is available for remote programming.

DOUGLAS lighting controls

www.DouglasLightingControls.com

1 Douglas 2-wire 24V Devices

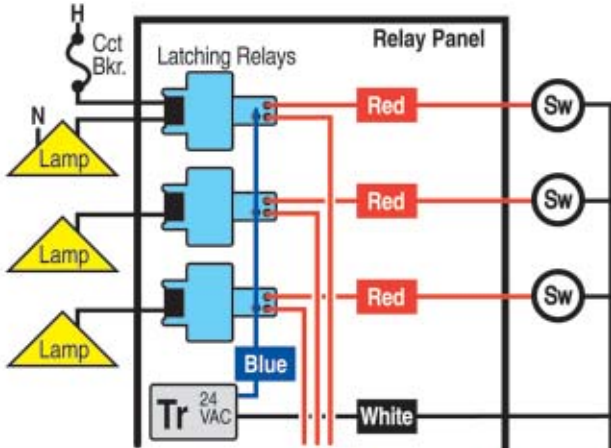

2 Standard 24V Controls



3 Hardwired Network

4 Digital Network

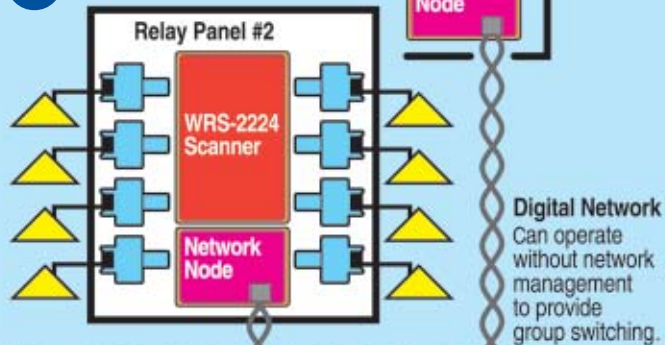

5 Network Management

Optional

WNP-2150 Network Manager

WNP-2150
Uses browser-based technology. Access system with an IP connection either directly or over the Internet.

OR

LonWorks Integration
The WNX-2624 Network Node is LonMark certified, as well as a number of other W-2000 components that can be integrated to be part of any B.A.S. that supports a LonWorks control system.

Other B.A.S. that uses the LonWorks Protocol

Douglas Products & W-2000 System

A W-2000 System is assembled using Douglas LonWorks products. They can combine to form single, stand-alone panels, hardwired networked panels, digitally networked panels or PC-configured systems.

The connection diagrams at the left illustrate the upgrade path available with the W-2000 System.

- 1 Start with basic panels, relays and switches.
- 2 Add group switching and basic photo/timer automation.
- 3 Create a simple hardwired network using a multi-conductor bus to allow control of multiple scanners and panels from a single group switch and/or photo/time clock control.
- 4 Plug a WNX-2624 Network Node into the WRS-2224 Scanner and create a digital network that allows all group switches and photo/time clock controls to be system wide.
- 5 Add the WNP-2150 Network Manager to expand the capability of the digital network and to permit PC control and programming. The interface is web based, so the PC can be connected directly or can access the WNP-2150 over the Internet.

Lighting controls can be selected and combined to suit the application. When designing a system, start with basic panels and add devices, controls, network options and digital controls as required for the project.

W-2000 System and the WNP-2150 Network Manager

A W-2000 System of networked scanners and nodes can function **WITH or WITHOUT** the WNP-2150 Network Manager.

Self-Configured Mode (WNP-2150 not installed)

When the WNP-2150 is not connected, the system is operating in the 'Self-Configured' mode. Other than the scanners and nodes, no further controls are required for network-wide group switching. Groups are programmed by using the membrane keypads built into every scanner/node combination. ON/OFF control, status, Flick Warn and Time Out controls are all available.

Externally-Configured Mode (WNP-2150 installed)

When the WNP-2150 is connected, the system begins operating in an 'Externally-Configured' mode. The WNP-2150 is required to view/edit the lighting control system. The lighting control software uses an internal web server as the interface. This approach has many advantages:

1. No special software has to be installed on the PC. Just use the standard web browser software (Internet Explorer®, Netscape Navigator® or equivalent) that is installed on the PC. Enter the IP address written on the WNP-2150 in the browser's address field to access the system.
2. Physical connection to the WNP-2150 is with an ethernet cord. Connect the WNP-2150 directly to a PC or to a LAN. If the WNP-2150 is connected to an Internet-enabled LAN, you can then access the lighting control system over the Internet.