

	PART No.	DESCRIPTION	SPECIFICATION
	<p>WNG-2122</p>	<ul style="list-style-type: none"> The WNG-2122 gateway allows a stand-alone Douglas system to operate independently, but gives an external LonWorks network access to switch all relay groups, obtain relay group status, switch any individual relays and obtain individual relay status within the Douglas system. The WNG-2122 streamlines the inclusion of a Douglas Lighting Controls network into a larger network and significantly reduces the time required to integrate the lighting controls network into the larger network. After integration, network management, node configuration and group programming will still be performed by the Douglas System. The WNG-2122 Gateway works with the Self-configured network, the WNP-2150-configured network or the MC-6000 network and allows the programming of the groups to be easily accomplished using the 'user friendly' Douglas interface. Implementing this device reduces the work involved in controlling a Douglas System with as many as 24 lighting control panels to the equivalent of configuring and binding ONE device. 	<p>Power</p> <ul style="list-style-type: none"> 24VAC, 100mA. <p>Outputs</p> <ul style="list-style-type: none"> Standard LonTalk transceiver, FTT-10 (78kbs) type. Data signals of both the LonWorks-based control network and the Douglas W-2000 LonWorks-based lighting control network connect to the Gateway unit. Wiring type for Douglas network side to be twisted pair, unshielded, #16 AWG. Connections are not polarity sensitive. <p>Network Technology Specification</p> <ul style="list-style-type: none"> Network signal: FTT-10 Transceiver. <p>Environment</p> <ul style="list-style-type: none"> Indoors, stationary, non-vibrating, non-corrosive atmosphere and non-condensing humidity. Ambient operating temperature: -0°F to +120°F (-15°C to +50°C).

**WNG-2122
LonWorks Gateway**

Install lighting gateway in a panel.
Connect external system's FTT-10 data signal to gateway.
Connect Douglas lighting control system's FTT-10 data signal to gateway.

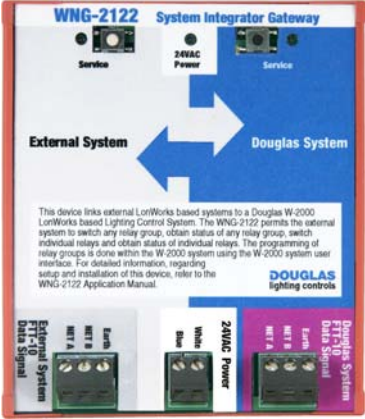
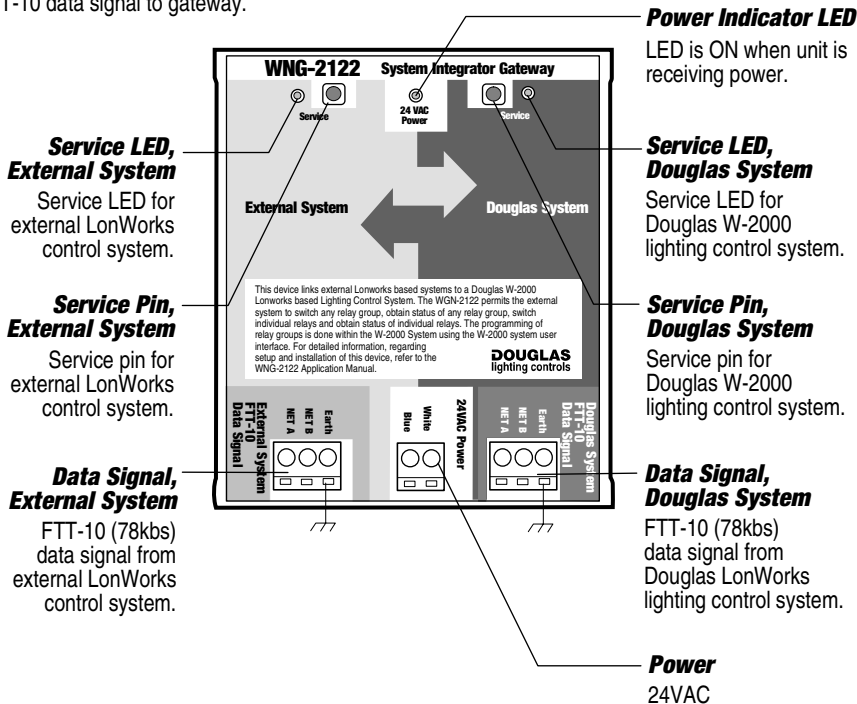

DIMENSIONS & MOUNTING

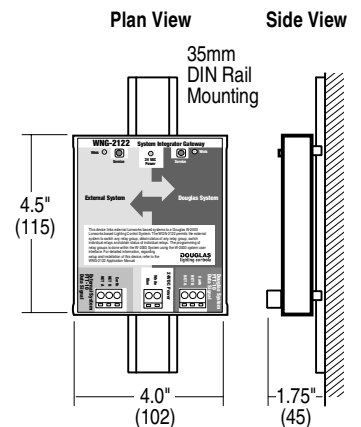

Advantages of utilizing a WNG-2122 Gateway in a LonWorks Network

This device will:

- Isolate the Douglas Lighting Controls subnet, thus relieving the task of lighting configuration from the intergrator.
- Allow Douglas tools to set up and bind the lighting portion of the network.
- Allow programming the lighting controls via the user-friendly W-2000 System interface.
- Allow an external system to track group status, regardless of which relays in the group are ON or OFF.
- Offer a single point of control for *SNVT_Scene* commands.
- Offer a single point to retrieve Group Status.
- If individual relay control or status is required, use *SNVT_State_64*. There is, however, a maximum of 24 WNX-2624 devices when using this approach. Installing multiple WNG-2122's will allow more Lon devices for individual relay control or status.

LONWORKS NETWORK DATA

This information is provided for system integrators who are integrating this device into an HVAC system.

To help with integration, software plug-ins for devices used in the Douglas Lonworks lighting control system are available.

Integrator Gateway Objects

