	PART No. WPS-5952 LonWorks Indoor Daylight Sensor WPS-5942 LonWorks Outdoor Daylight Sensor	DESCRIPTION <ul style="list-style-type: none"> The WPS-5952 LonWorks Indoor Daylight Sensor and WPS-5942 LonWorks Outdoor Daylight Sensor are designed to report the measured light level in lux to the W-2000 System or any other LonWorks network. The Sensors each are autoranging and can provide readings from 0 to 65,535 lux. Each Sensor can provide a digital value up to 5 times a second. 	SPECIFICATION Power <ul style="list-style-type: none"> 24VAC supply, 15ma. Output <ul style="list-style-type: none"> The WPS-5952 and WPS-5942 Sensors are each a microprocessor driven device that is autoranging and accurate to within ±10%. Sensor head outputs a digital signal compatible with LonWorks networks. Provides light level values from 0 to 65,535 lux. Data Signal: FTT-10 Transceiver (78bps). Wiring method dependent upon network installation. Refer to LonWorks Network wiring documentation. Networking Technology Specification <ul style="list-style-type: none"> LonWorks Technology. Environment WPS-5952 INDOOR DAYLIGHT SENSOR: <ul style="list-style-type: none"> Indoors, stationary, non-vibrating, non-corrosive atmosphere and non-condensing humidity. Ambient operating temperature: -15°F to +130°F (-25°C to +55°C). WPS-5942 OUTDOOR DAYLIGHT SENSOR: <ul style="list-style-type: none"> Stationary, non-vibrating, non-corrosive atmosphere. Ambient operating temperature: powered: -55°F to +130°F (-50°C to +55°C), unpowered: -10°F to +130°F (-25°C to +55°C). Sensor is watertight and able to withstand direct rain and snow. Mount sensor to avoid coverage by snow and ice.
---	--	--	---

CONNECTIONS & INSTALLATION: WPS-5952

Wink LED

Used by a LonWorks® network to locate a device. Normally the wink LED is OFF.

Service LED

Used by a LonWorks® network to indicate that the device is in a configuration mode. Normally the service LED is OFF.

front of Sensor with snap-on cover removed

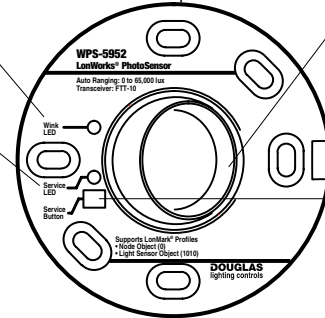

Swivel and Rotate Eyeball

Used to align sensor to most accurately measure available light. Sensor element is recessed so that side lighting effects are minimized.

Service Button

Used to signal the device to broadcast its presence to a LonWorks® network. Pressing and holding the service button will erase all configuration settings.

Positioning

- The sensor measures the light reflected from the surface below. Direct light from uplights or light reflected from shiny surfaces (polished floors) or very dark surfaces will yield poor results.
- Try to locate the sensor so the surface it sees below is likely to remain the same once the building is occupied. For instance, avoid a desktop surface because reflectivity can change depending on the amount of paper on it. Good locations are a matte-finished floor such as a neutral colored carpet.
- Never allow artificial light to shine directly on the WPS-5952 Sensor.
- For skylight applications use either the WPS-5952 Indoor Sensor or WPS-5942 Outdoor Sensor, depending on whether open loop or closed loop daylight control is required.

Connections

Data Signal: FTT-10 (78kbs)
Power: 24VAC

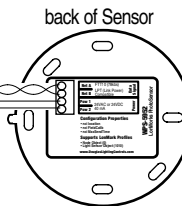

LONWORKS NETWORK DATA

This information is provided for the benefit of System Integrators who are integrating these devices into a system. To help with integration, software plug-ins for the LNS system are available.

Functional Profiles

- Node Object Type: 0
- Light sensor type: 1010

Network Variables

- NvoLuxLevel reports current lux readings at rate specified by nciMaxSendTime.
 - NvoTemperature reports current sensor temperature.
- Note: The WPS-5942 Exterior Sensor has an internal thermostat/heater circuit. The thermostat activates at -10° F (-25C). Thus, nvoTemperature will not report ambient values correctly when the ambient is cold.

LonMark Profiles

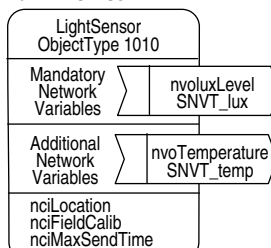

CONNECTIONS & INSTALLATION: WPS-5942

- The WPS-5942 Sensor is weatherproof and designed to withstand harsh climate. However, mount the sensor, when possible, either indoors pointing outward or in a sheltered area so the sensor's measurements will be less affected by dirt, snow or ice buildup. If mounting outdoors, try to shelter the sensor from the elements. For example, mount the sensor on the underside of the junction box.
- The sensor has a plastic mounting nipple that can be threaded to a 1/2" pipe thread. A mounting nut is also supplied to suit mounting to a 1/2" knockout.
- Do not mount the WPS-5942 Sensor so that artificial light shines directly on it.

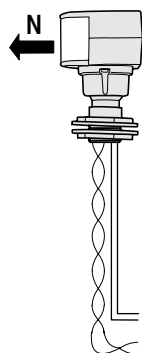

If mounting outdoors, point Sensor to northern sky for most consistent readings.

Connections

Power: 24VAC
Data Signal: FTT-10(78kbs)

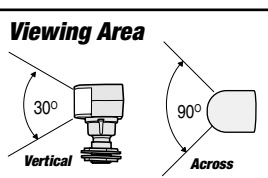

DIMENSIONS & MOUNTING

WPS-5952 INDOOR DAYLIGHT SENSOR

- Unit attaches to mounting ring with screws

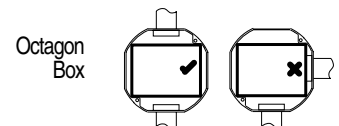
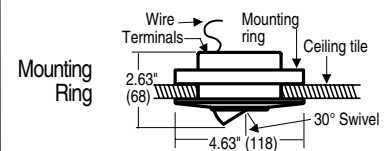

- attach conduit to opposite ends.

WPS-5942 OUTDOOR DAYLIGHT SENSOR

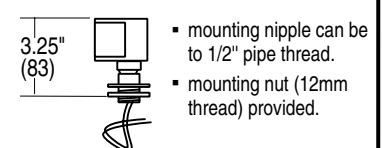

- mounting nipple can be to 1/2" pipe thread.
- mounting nut (12mm thread) provided.