



PART No.	DESCRIPTION	SPECIFICATION
<p>MC-6000 System</p> <ul style="list-style-type: none"> MC-6210 CPU MC-6308 Input MC-6416 Output 	<ul style="list-style-type: none"> The MC-6000 System is a full featured lighting control system that can be networked to include relay panels, dimming panels, and PC computers. The MC-6000 System is typically used for complex or larger scale projects. It is ideal for office towers, shopping centers, stadiums, and institutional buildings. Each relay panel is equipped with an MC-6000 interface unit. The unit contains all of the programs and functions assigned to it in its on-board memory. This ensures speedy response to user inputs. The MC-6000 interface units installed in each of the panels are networked together with a 2-wire data signal. A PC connected to the data signal is used to program the system, retrieve logging information and to manually switch and monitor any relay or groups of relays in the system. An MC-6000 interface unit can also be used in the stand alone MC-6000A format. Programming is accomplished with the hand held unit KB-3031. 	<p>Inputs & Outputs</p> <ul style="list-style-type: none"> Modular construction. Input and Output units plug into the host CPU unit to form an MC-6000 interface unit. The MC-6210 CPU can host up to 8 MC-6308 Switch Input units (64 inputs total) and 4 MC-6416 Relay Output units (64 outputs total). An MC-6308 Input unit has 8 inputs compatible with Douglas relay switches or momentary/maintained contacts. An MC-6416 Output unit has 16 outputs compatible with all models of Douglas 2-wire relay. MC-6000 interface units are networked with a 2-wire, RS-485 signal. Up to 249 interface units can exist in a network. <p>Programming Controls</p> <ul style="list-style-type: none"> Programming the lighting control system is done with a remote PC connected to system's data signal. The MC-6000 system software runs on Windows 95/98, NT, Win2000 or XP operating systems. Software features include: <ul style="list-style-type: none"> relay group assignments weekly & holiday time schedules switch input & time schedule functions switch configuration options include on/off, flick-warn, time-out, delay-off and priority masking. Options are viewed and set with the PC software. Central software graphic manual override available with the central software modules. All programs (except building graphic) are resident in the MC-6000 panel interfaces, not the PC. Relay panels function even when the PC is off-line. Programming is not lost when power is turned off to an MC-6000 interface. Memory capacity for definitions for each MC-6000 interface are: <ul style="list-style-type: none"> Individual adjustment for each input and/or schedule (Flick-warn: 0-99min, Time-out: 0-999min, Delay-off: 0-99). 128 input programs 128 holidays Date/Time Date: YY-MM-DD Time: HH-MM (24 hour format)

MC-6000 Panel Interface Units

MC-6000 interface assemblies consist of a CPU unit that has Input and Output modules plugged into it. MC-6000 interface assemblies are networked to form a building wide lighting control system. Programming and monitoring is done with a PC.

Interface Connector

Interface modules are mounted on a DIN rail located in between the relays. Successive units plug into the connectors to form a complete interface assembly.

Error LED

(also on MC-6416 & MC-6210)

Panel Bus Indicators

(also on MC-6416 & MC-6210)

Reset Button

Reset button for re-booting interface.

System Address Setting

Each MC-6210 CPU has a unique address that identifies it to the lighting control system. Up to 249 MC-6210 units can exist in a network.

Data Signal

The MC-6000 system uses an RS-485 data signal. Wire is a twisted, shielded pair with a ground wire.

Twisted pair
Ground wire

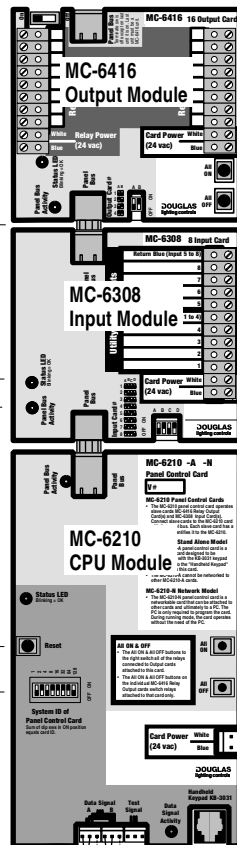

Relay Outputs

16 relay outputs (8 per side) that operate Douglas 2-wire relays.

On-board Overrides

ON and OFF scan buttons provide All ON and All OFF override control of relays connected to the module.

Inputs

8 switch inputs compatible with Douglas relay switches or with contact closures.

Address Switch

(also on MC-6416 unit) Each module has an address switch that uniquely identifies it to the MC-6210 CPU card.

Brief System Description

A brief description of the system exists on the label to familiarize service personnel with the basic function of the MC-6000 unit.

24VAC Power

Connections for 24VAC Power.

MC-6000A Option

The MC-6000 interface unit can be used in a stand-alone format. Plug the KB-3031 hand unit into this connector.

DIMENSIONS & MOUNTING

- Each MC-6000 interface consists of a CPU unit, input and output modules.
- The interfaces are installed in between the 2 rows of relays in the panel on a 35mm DIN rail.

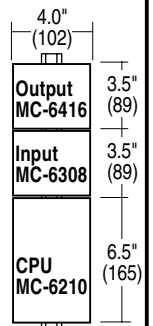

Office Floor - Reflected Ceiling Plan

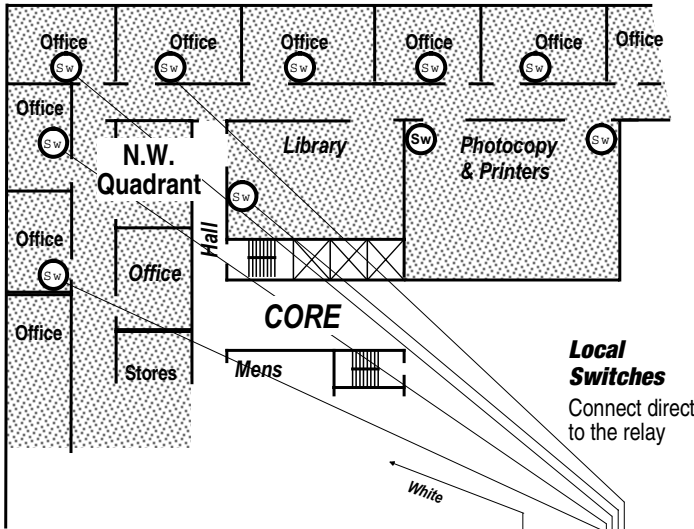

Local Switches
Connect direct to the relay

CONNECTIONS

Individual, Master and Central Control

- To switch only an individual relay, connect the Douglas wall switch directly to the relay. Response is instant, wiring is simple and no programming required.
- Master control of several relays is accomplished by connecting the Douglas wall switch to an input of the MC-6308. Program the input to switch any relay or group of relays in the system.
- Other devices such as key switches, photosensors and contacts from other devices or systems can also be connected to an MC-6308 input to actuate a relay or group of relays (not shown).
- The outputs of the MC-6416 control and monitor the state of the relay connected to an output. The MC-6210 holds the programs and provides the link to the rest of the lighting control system.

Relay Group	Lighting Circuit
1	NW Priv Office
1	NW Priv Office
1	Library
1	Library
1	NW Priv Office
1	NW Priv Office
1	NW Priv Office
5	Hall
5	Hall
5	Elevator Lobby
5	Mens WC
5	Ladies WC

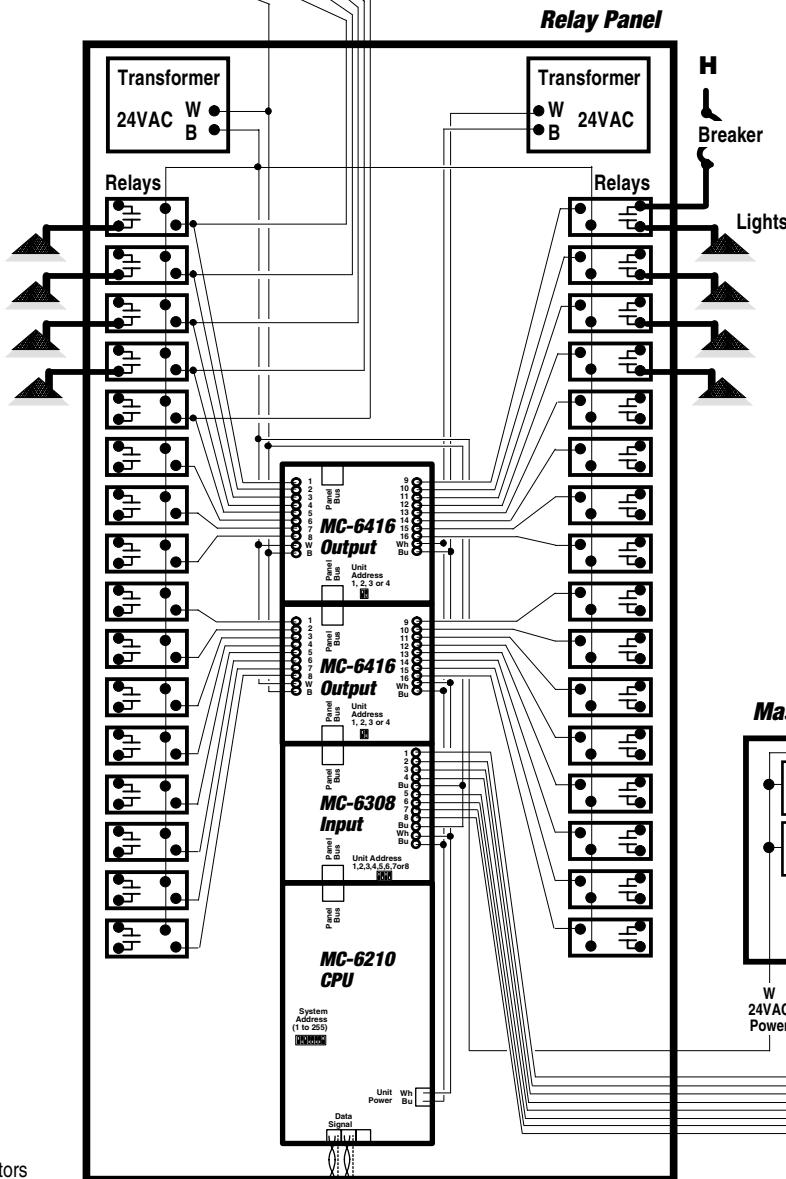

Master Switch Station

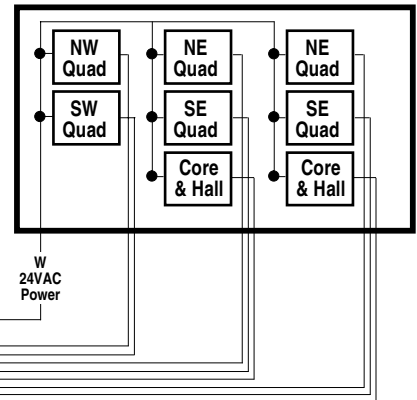

Data Signal

- RS-485 Signal
- Twisted, shielded pair conductors and ground wire

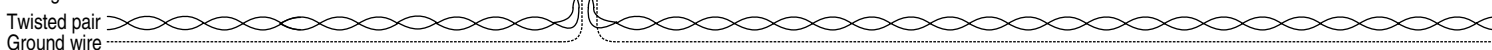

CONNECTIONS & PROGRAMMING

Typical Scheduling

- Scheduled switching of lighting circuits will yield significant energy savings. A common application is to schedule periodic OFF signals during unoccupied hours to ensure lights are OFF.
- Install wall switches to provide for occupant override. This can be either individual switches connected directly to the relays and/or master switches connected to the MC-6000 interface.
- Program periodic OFF signals (typically 2 hours) during unoccupied hours. The interface can be set to provide a "Flick-warn before OFF" prior to executing an off schedule.
- Programming ON signals is optional; better energy savings result if lights are turned ON manually by wall switch(es).
- Schedules have a variety of features that can be applied to suit any situation. Schedules can be set to be only operational for certain times of the year (eg: XMas shopping hours), can be set to disable switches for certain time periods during the day (prevents nuisance switching) and can be set to occur at different times on different days.

Master Switch Inputs

- The input is configured to be compatible with the device connected to it. The default configuration is a Douglas 2-Wire relay switch. To change the configuration of the input use the software on the PC to access the input and select a different option. Configuration options available are:
 - 1) Douglas Relay Switch (ON & OFF)
 - 2) Douglas Relay Switch (OFF & ON)
 - 3) 24V Contact*: ON signal on closure, OFF signal on opening
 - 4) 24V Contact*: ON signal on closure, NOTHING on opening
 - 5) 24V Contact*: NOTHING on closure, OFF signal on opening
 - 6) 24V Contact*: OFF signal on closure, ON signal on opening
 - 7) 24V Contact*: OFF signal on closure, NOTHING on opening
 - 8) 24V Contact*: NOTHING on closure, ON on opening

* 24V Contact is a dry contact that passes a 24VAC signal.
- With the PC computer, define a group of relays and assign that group a name. Then for the switch input, assign the relay group name to respond to that input. You can also assign the same relay group name to a schedule to automate the relay group.

PC Interface

- The actual software that runs the lighting control system resides in the MC-6210 CPU Modules that are installed in the relay panels. The MC-6210 Modules run independently and do not require that a PC is connected to the system.
- The PC user interface permits query and adjustment of programs resident in the MC-6210's. The PC can also be used as a switch station that displays the true state of the relays and groups and permits real-time switching of any relay or group of relays in the system. Standard switching interface is tabular in design and graphical interfaces are also supported as an option.
- Logging and trend analysis of when relays are switched is useful for re-lamping analysis, power analysis and surveillance of actual usage of lighting circuits.
- Graphical interfaces require initial artwork to be done from the AutoCad files of the project. Drawings are simplified and rebuilt as required to form an underlay for lamp symbols and switch icons imposed on top. The lamps and switches are interactive with the system and will display the true state of the relays and will switch in real time by clicking on switch icons. Zoom features permit drill down to localized areas. Thus there are usually several graphic screens required for a project.
- The MC-6000 software runs on Windows NT, Windows 2000, Windows XP, or Windows Vista equipped PCs. To connect to the system, an RS-485 interface to Comm port or USB port card is provided (laptop or desktop versions).

Relay Panel

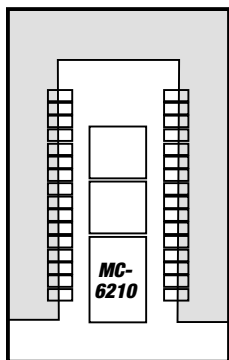

Relay Panel

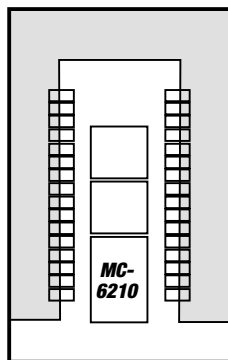

PC Interface Control and Programming



MC-6000 SYSTEM FEATURES

Standard Hardware Features

- Desktop PC and/or Laptop operator's terminal
- True relay status (monitoring of each relay coil)
- Local/master low voltage switch capability
- Pre-wired relays and programmable inputs
- Battery backed up memory / time clock
- UL listed / CSA approved

Standard Software Features

- Operates on Windows 95/98, NT, Win2000 or XP Systems
- Time event scheduling
- Manual override control (masking, ON/OFF and flick)
- Holiday and special day scheduling
- Occupancy warning (remote supervision)
- Power usage logging
- Peak demand monitoring
- Total energy consumption record
- Tenant billing
- Lamping

Optional Features

- Laptop operator's terminal
- Custom graphics for manual control
- Telephone override
- Event printer

INSTALLATION

- The Douglas relays are factory installed and pre-wired to the MC-6000 interface outputs in the relay panel. To network the panels, run the 2 wire data signal in a serial line from panel to panel. The data signal is standard RS-485 signal that requires a twisted #20 AWG wire pair in a cable with a foil shield.
- Connect standard Douglas 2-wire switches direct to relays to operate individual lighting relays. Connect Douglas 2-wire switches to contact inputs to operate relay groups. Use #18 AWG solid conductor for switch connections.
- Install switches at convenient locations and program master switches and schedules as required with the PC.
- Optional telephone interface permits occupants to switch lights via telephone. User dials in and enters passcode to switch lights.

Typical One-line Diagram of MC-6000 System

