

	<b>PART No.</b>	<b>DESCRIPTION</b>	<b>SPECIFICATION</b>
	<p><b>WPC-5621K</b></p>	<ul style="list-style-type: none"> <li>Use the WPC-5621K Daylight Sensor for indoor applications. Turn lights OFF and ON in step with natural, ambient lighting. All adjustments are conveniently located under the front, snap-on cover.</li> <li>The WPC-5621K can switch Douglas 2-wire relays directly or can signal other systems with its auxiliary output contacts.</li> <li>Mount sensor on ceiling (maximum height: 12') to measure the light reflected from the surface below. Unit is adjustable and will switch lights OFF and ON at the set values.</li> <li>The sensor lens can be rotated or swiveled to allow monitoring of the most appropriate surface.</li> </ul>	<p><b>Inputs</b></p> <ul style="list-style-type: none"> <li>Power: 24VAC / 30mA Class 2 Low Voltage device.</li> <li>Power rating does not include power used to switch relays.</li> <li>Remote enable input is used to enable and disable the WPC-5621K Daylight Sensor.</li> </ul> <p><b>Outputs</b></p> <ul style="list-style-type: none"> <li>ONE Douglas 2-wire relay output. Connect a maximum of 4 relays to this output. Use #18AWG wire.</li> <li>Auxiliary output contact set. ON contact closes when light drops below the set point. OFF contact closes when light goes above the setpoint.</li> <li>Auxiliary contacts are rated at 30V, 1A.</li> </ul>

**WPC-5621K Daylight Sensor**  
(Front view of sensor with snap-on cover removed)

**Time Delay and Power Setting**

Press button to toggle between Normal (180 sec. delay) and Test (5 sec. delay) mode.

Green LED on indicates Normal mode and Red LED on indicates Test Mode.

Press and hold button for 3 seconds to turn power off.

**Range Select**

Four ranges can be selected.

Ranges are 300, 600, 2000 and 5000 lux.

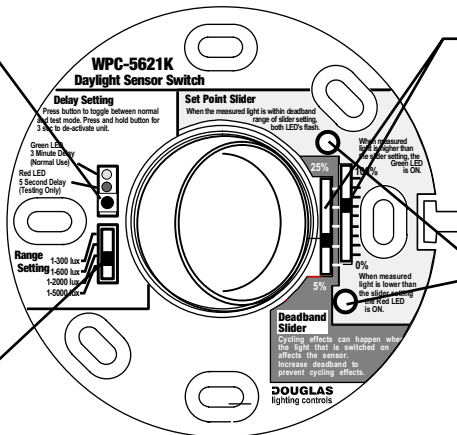

**Set Point & Deadband Adjustments**

Setpoint slider sets switching level. Deadband slider widens setpoint to prevent cycling.

**LED Indicators**

Two LEDs indicate if the measured light is above, in between or below the setpoint.

**Photocell Adjustments**

- Sensing element is photo diode type that is color corrected for ambient light applications.
- Ranges: 300, 600, 2000 and 5000 lux.
- There is a setpoint slider to adjust at what light level the sensor shall switch.
- There is a deadband slider that adjusts how wide the setpoint is. This is used to prevent the sensor from cycling.
- Time delay of switching response is selectable between 5 sec. for testing or 3. min for normal use.

**Environment**

- Indoors, stationary, non-vibrating, non-corrosive atmosphere and non-condensing humidity.
- Ambient operating temperature: +15° to +120°F (-10° to +50°C)

**DIMENSIONS & MOUNTING**

- Unit attaches to mounting ring with screws or it can be mounted to an octagon box.

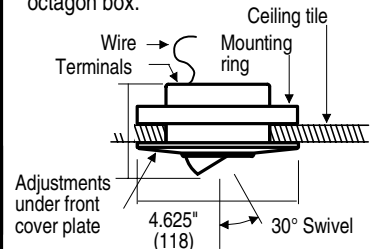

- The WPC-5621K fully occupies an octagon box. It is very important that conduit be attached at opposite ends of the box.

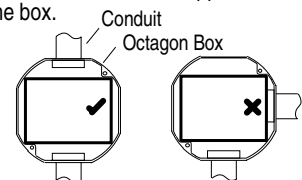

- Use a 2" or more deep box. If the box is 1.5", use the mounting/spacer ring.

**CONNECTIONS**

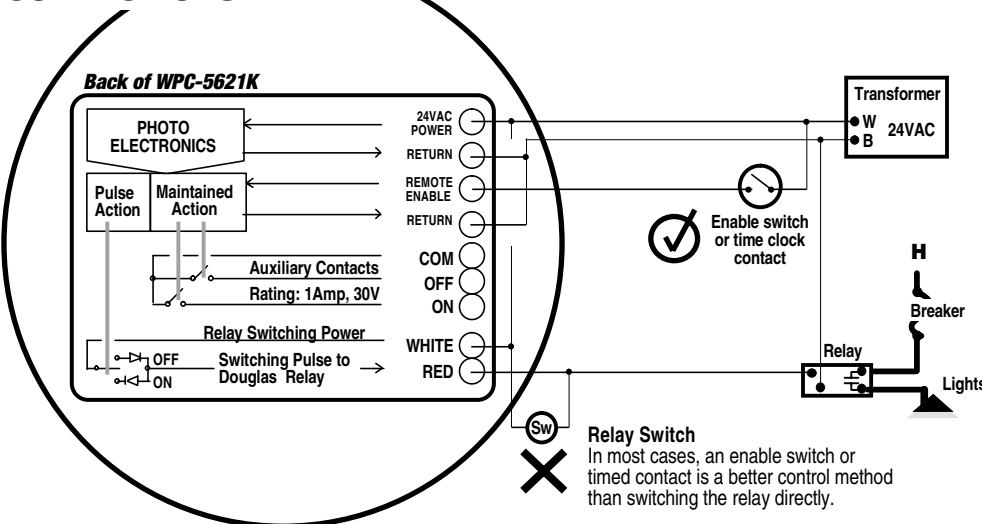

**APPLICATION & INSTALLATION**

- The WPC-5621K Daylight Sensor is designed for applications that measure light reflected from the floor. Do not use a WPC-5621K sensor to measure direct or brightly reflected sunlight. Use the WPC-5577 for these applications.
- There is a significant trend towards constructing buildings that make better use of daylight. Buildings that take advantage of daylight as an illuminant are often more pleasant and desirable structures. It is very important to understand that natural light includes light on moderately overcast days. It can be demonstrated that the light available on moderately cloudy days is very similar to the amount available on sunny days. In fact, in some cases the light entering the building on moderately cloudy days can exceed that of sunny days due to reflections off clouds.
- Buildings located in overcast, rainy climates can be designed with effective sizing and placement of glass to provide reasonable amounts of natural light into regular office spaces. In many cases, it is not difficult to use natural light for at least 35% of the total annual daylight hours.
- Daylight controls must be able to tell the difference between a very cloudy day and a less cloudy day. The WPC-5621K sensor is an accurate, microprocessor controlled device designed to give stable measurement of the ambient light in a room.
- Daylight controls that switch artificial lights OFF and ON in step with the natural lighting can provide significant savings in addition to regular time or occupancy based controls. Buildings that use Douglas lighting control equipment can take advantage of Douglas daylight sensors to capture these savings.

- Application of daylight ON/OFF control must be made with some care. In circulation areas such as a hallway, concourse or lobby, ON/OFF control causes minimal disruption. However in work spaces, daylight controls can be disruptive. Some tips are:
  - 1) The human eye can barely detect a 10% change in intensity. Try to position and select lamps so that less than this amount occurs.
  - 2) Fluorescent fixtures - switch the center or outer tubes of a strip of fixtures along the window. Avoid switching every second fixture as this will cause light imbalance in the space.
  - 3) In most cases, switch lighting that is installed parallel to the natural light source. Fluorescent lamps that are installed parallel to the windows are excellent candidates.

**ENERGY SAVINGS INFORMATION**

- The switching of lamps with photometric controls can yield considerable energy savings. Savings will differ from application to application and will vary according to electrical rates.
- Assuming a 35% lights OFF time during the day and an average daytime length of 12 hours (6AM to 6PM) yields approximately 4 hours of OFF time available per day. There are 250 business days total 1000 OFF hours available per year (4hrs x 250days). Assuming a \$0.05 electric rate per KWH, a savings of \$50 can be realized for each 1000W of lighting load. Main entrance foyers of larger buildings can have lighting loads that exceed 1000W by many times.

**SWITCHING SEQUENCE for WPC-5621K**

