

	PART No.	DESCRIPTION	SPECIFICATION
	WRM-5104	<ul style="list-style-type: none"> ▪ Ceiling mount PIR occupancy detector designed to switch Douglas 2-wire relays, operate power cube devices or signal other systems. ▪ Use indoors only. The detector is ideal for 8 to 12 foot high ceilings. Maximum height is 16 feet at which only walking motion can be detected. ▪ Adjustments are under the detector's front cover. ▪ Upon sensing motion, the detector signals ON and starts an internal timer. Whenever motion is sensed, the timer is reset. If no motion occurs and the timer expires, the detector signals OFF. 	<p>Inputs</p> <ul style="list-style-type: none"> ▪ Power: 24VAC or DC - 20mA Class 2 Low Voltage device. ▪ Use #18 AWG wire. <p>External Inputs</p> <ul style="list-style-type: none"> ▪ The slave trigger input permits several detectors to work together for larger area coverage. <p>Outputs</p> <ul style="list-style-type: none"> ▪ Douglas 2-wire relay outputs: 4. Maximum relays per output: 2. All outputs are isolated from each other. Max wire length is 500' (150m). ▪ Auxiliary contact. 1A / 30VAC rating. Contact is form A type: NO - COM.

WRM-5104 Occupancy Sensor
(front view of sensor with snap-on cover removed)

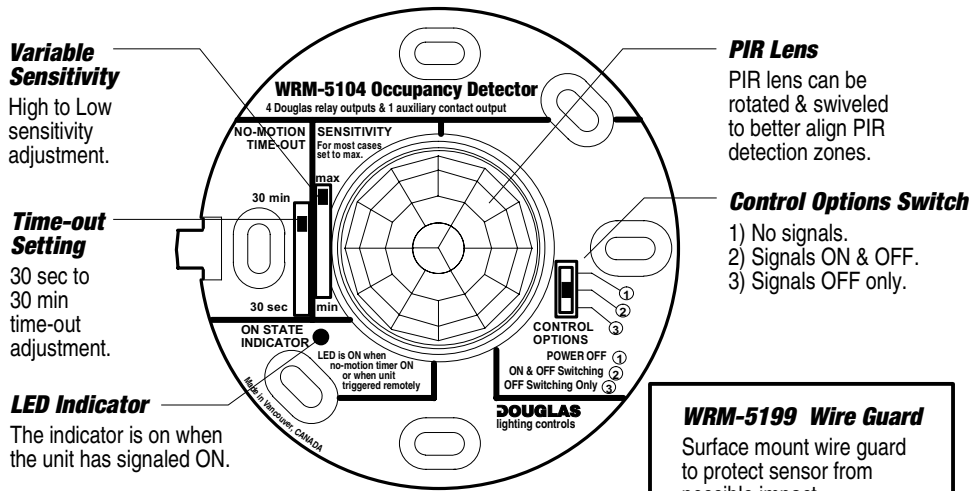

COVERAGE PATTERN

- The WRM-5104 occupancy detector is ceiling mounted and has the 360° detection pattern shown at left. The pattern of the detection zones is shaped like the quills of an upside down porcupine.
- The ideal mounting height is between 8 and 12 feet. Detectors mounted above 12 feet will only be able to detect walking motion. Detectors mounted below 8 feet will have reduced coverage area.
- If the activity in the room is primarily of sitting nature and there is little traffic, then the handwave range should be used. In larger rooms several detectors may be required for proper coverage.
- If there is occasional traffic then the walking motion range can be used. If walking motion does not occur very often, increase the no-motion timer setting to prevent false OFF signals.
- In rooms larger than 15' x 15' the best location is usually in the center of the room. In rooms smaller than 15' x 15' the best location is usually to one side of the room. In small rooms, try to position the detector so that detection zones do not point out entrances.

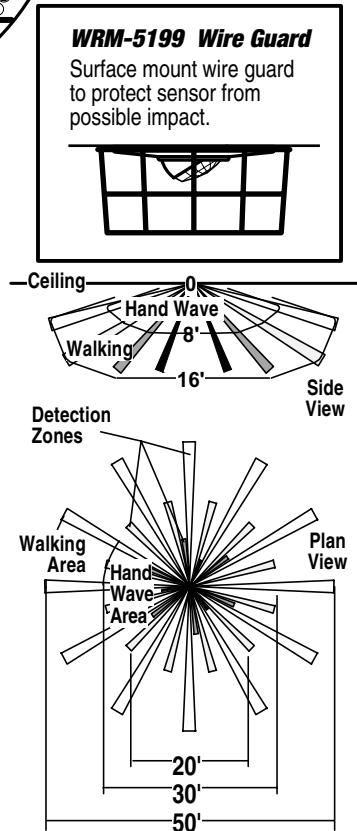

- Adjustments**
- Adjustable time out (30sec to 30min).
 - Adjustable sensitivity.
 - Rotate & Swivel sensor head.
 - Adjustable control options:
 - 1) ON & OFF relay switching
 - 2) OFF only relay switching.
 Auxiliary contact is unaffected by the control option setting.
 - Directions are printed on the front of the sensor & inside of the cover plate for convenient user reference.
- Environment**
- Indoors, stationary, non-vibrating, non-corrosive atmosphere and non-condensing humidity.
 - Ambient temperature: +15° to +120°F (-10°C to 50°C)

DIMENSIONS & MOUNTING

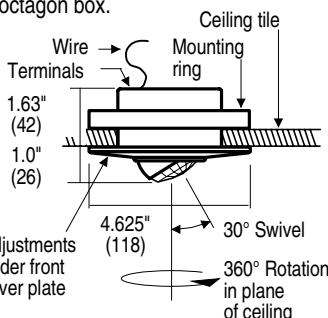
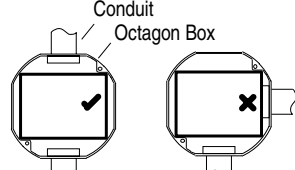
- Unit attaches to mounting ring with screws or it can be mounted to an octagon box.
- 
- Wire Terminals, Ceiling tile, Mounting ring, 1.63" (42), 1.0" (26), 4.625" (118), 30° Swivel, 360° Rotation in plane of ceiling
- The WRM-5104 fills an octagon box. It is very important that conduit be attached at opposite ends of the box.
- 
- Conduit, Octagon Box
- Use a 2" or more deep box. If the box is 1.5", use the mounting/spacer ring.

CONNECTIONS

WRM-5104 & Douglas 2-wire Relays

- The WRM-5104 has 4 outputs for Douglas 2-Wire Relays. This is useful for applications that require the detector to switch several relays together and local wall switches to switch relays individually. Classrooms and boardrooms are typical applications.

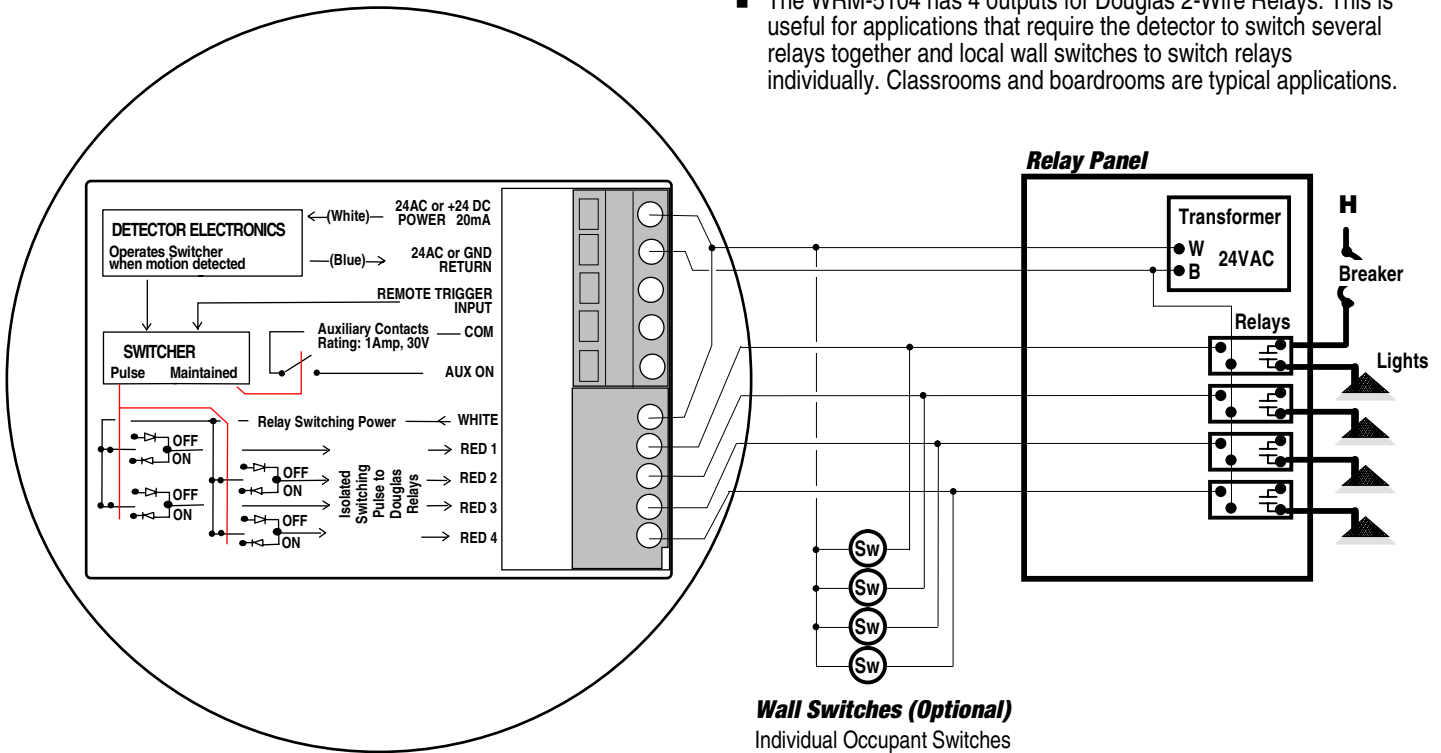

Wall Switches (Optional)
Individual Occupant Switches

WRM-5104 & Signaling other Systems

- The WRM-5104 has an auxiliary contact that can be used to signal other devices and/or systems. The contact is closed and stays closed until there is no more occupancy detected. To power the detector, use a 24VAC control transformer or if your device/system has a 24 VAC or VDC supply use it. The detector's power requirement is very low (20mA).

WRM-5104 & Power Cube Applications

- The WRM-5104 can be used with standard 24VDC Power Cube Devices. Connect as shown in the schematic. When the auxiliary contact closes, the Power Cube closes the lighting load contact. When the auxiliary contact opens, the Power Cube opens the lighting load contact.

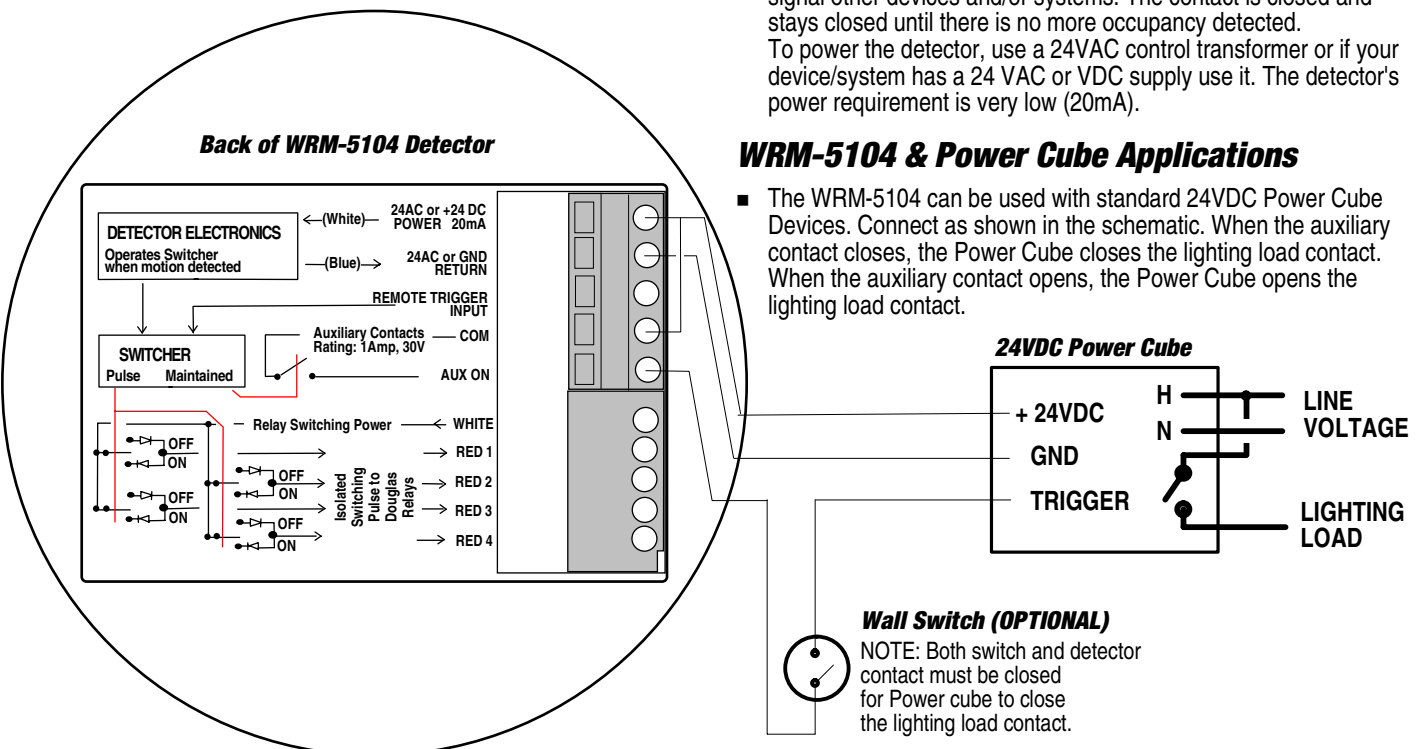

Wall Switch (OPTIONAL)

NOTE: Both switch and detector contact must be closed for Power cube to close the lighting load contact.

CONNECTIONS

Multiple Detectors to Increase Coverage Area

- To increase coverage area, extra detectors can be designated as slave detectors. The auxiliary contacts of the slave detectors are all connected in parallel to the primary detector's slave input.
- If any one of the detectors (slave or primary) changes to the ON state, the primary detector will issue an ON signal. For an OFF signal to occur, all of the detector's no-motion timers must have expired. When the last expires, an OFF signal is issued.
- The maximum number of slave detectors is limited by the transformer size. 20 slave detectors would need 400mA (20 x 20mA). All Douglas transformers can accommodate this load.

Placement of Multiple Detectors

- In rooms such as classrooms (40'x40' or less) one detector is often sufficient. Handwave motion is detected in the center area and walking motion is detected around the perimeter.
- In larger spaces, determine if the detection requirement is for walking or handwave motion. Consider traffic patterns and/or where occupants will be sitting when laying out the detectors.
- For open areas such as a cafeteria or open office plan, position the detectors in a grid. Modify the grid if there are partitions or obstructions.

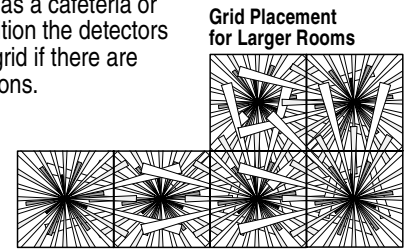
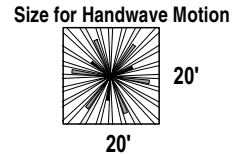
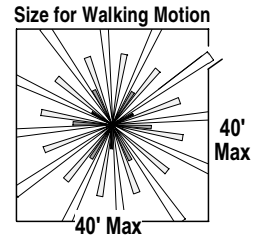

- For hallway applications, it is recommended that detectors be spaced no more than 30' apart. Since most traffic travels parallel to the detection zones instead of across them, the range of detection will be decreased.

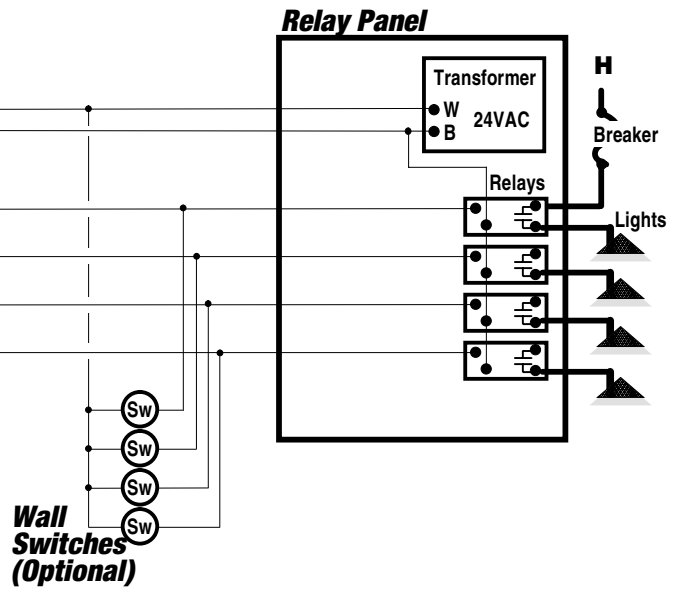
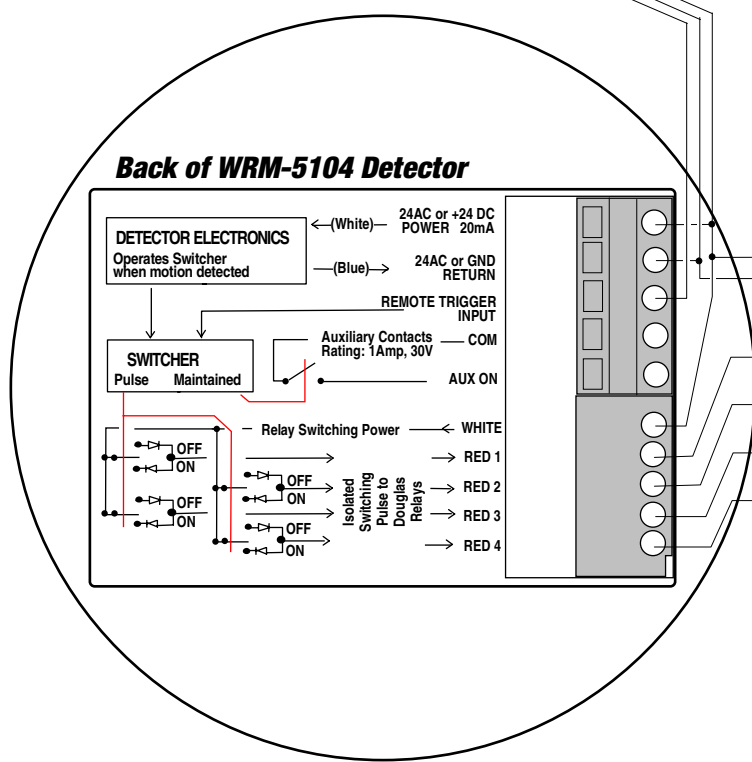
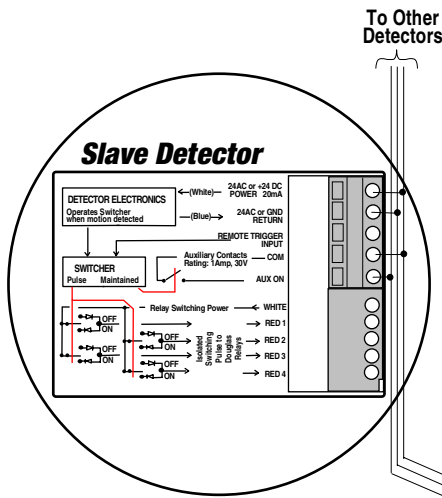
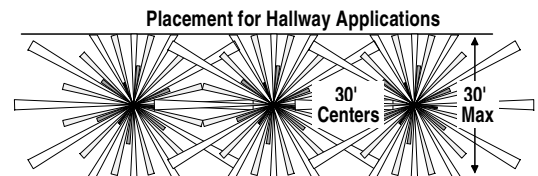

B-4.1,2,3,4 -Auto, Sensor Sw, Occupancy

INSTALLATION

Method of Detection - PIR

- WRM-5100 series detectors use **Passive Infra Red** (PIR) technology. All objects emit a specific infra-red frequency that is dependent upon the temperature of the object. PIR occupancy detectors are optical devices that are tuned to detect the infra-red frequency emitted from people (98°F).
- It is the **movement** of the infra-red source (walking or a handwave) that is "seen" by the detector. The detector accomplishes this by having several small lenses that each focus a zone onto a sensing element. As the person travels in to and out of a zone, the amount of infra-red light focused on the element changes. This is interpreted as motion.
- Movements **across** a focus zone cause a stronger motion signal than movements **parallel** to a detection zone. When locating PIR occupancy detectors, try to maximize the probability of movements across the detection pattern.

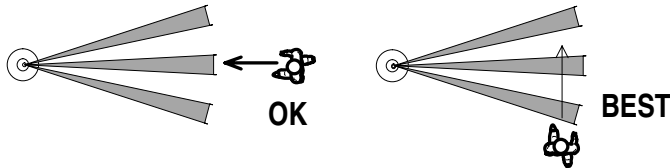

- The amount of infra-red light focused on the sensing element is greater from objects that are close than from objects that are distant. Only at close range (less than 15') is handwave motion detectable. At greater distances (15' to 25') only walking motion is detectable.

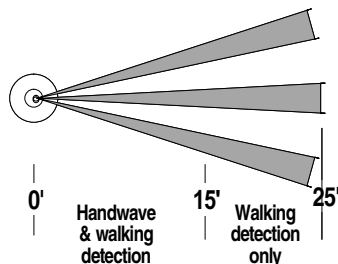

- The WRM-5104 detector is designed for ceilings that are from 8 to 16 feet high. Handwave motion is only possible for ceilings 12' or less. Walking motion can be detected from 16' ceilings. Do not use the WRM-5104 detector on ceilings higher than 16'.

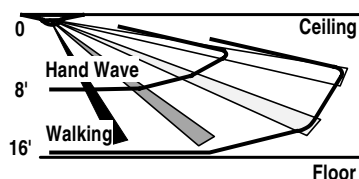

Solid Objects

- Detection cannot be made through solid objects (partitions or bookshelves). Position detector(s) so that there are no obstructions.

Forced Air Vents

- Locate detector away from forced air vents (4 feet or more). Large amounts of hot, moving air can be detected which causes false tripping. If this problem is occurring, try reducing the sensitivity. The swivel or rotation feature may also help reduce false tripping from air vents.

Detection Zone Alignment

- The WRM-5104 sensor has alignment features to help optimize the performance of the sensor for your application.

Rotation

- The rotation feature permits the detection zones to be precisely aligned with entrance ways. This will ensure immediate detection upon entry.

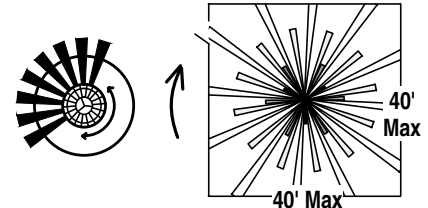

Swivel

- If detection is occurring from traffic exterior to the room (1), use swivel feature to aim detection zone at the bottom of the doorway (2).

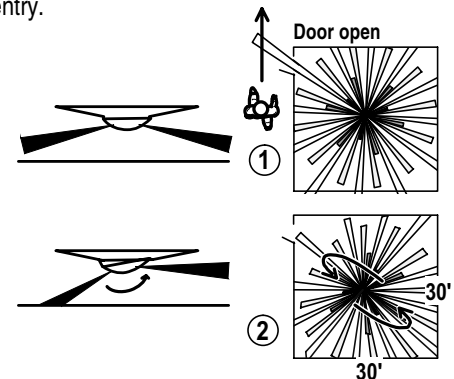

ENERGY SAVINGS INFORMATION

- To calculate the energy savings, examine your application to first estimate the amount of extra off time that could be obtained for over the course of a whole year.
- For example, consider a school classroom. Assume that the classroom is used for regular school and occasional night school. The following assumptions are made for this example:
 - Between the hours of 8:00AM and 10:00 PM (14 hrs. total) the room is occupied for 8 hours.
 - If there is no automatic control, lights are likely to be left ON for the full 14 hours. Thus, there are at least 6 hours per day of available off time (14 hrs total - 8 hrs occupancy).
 - Since there are only 5 school days in a week, and 40 weeks of use, there are a total of 1200 hours (6hrs x 5days x 40weeks) of off time available.
- The second step to calculate energy savings is to determine the KWH (Kilo Watt Hour) load. Electrical utilities bill electricity by this unit of measure. One KWH is equal to running a 1 Kilo-Watt (1000W) lighting load for one hour.
- For the classroom example:
 - There are 25, 4 lamp fluorescent fixtures. Each lamp is a 40W lamp.
 - The total load is then 4000W (25 fixtures x 4 lamps x 40W).
 - The hourly KWH load is then 4 KWH (4000W ÷ 1000).
 - Determine your electrical rate. For this example we will assume a \$0.05 rate. Therefore, a 4 KW load will cost \$0.20 per hour to operate.
 - Since there are 1200 hours of estimated off time available, the total savings should be at least \$240.00 (\$0.20 x 1200hrs).
- The savings calculated above do not include late night savings and weekend savings. These savings will add significantly to the total. Payback for this installation should be less than one year.